

TECH4FOOD MAGAZINE

DESIGN • KNOW HOW • INNOVATION • VISION

Managing director: Angelo Frigerio

Year 4 • N.3
October/November 2020

**Each country has its own cheese:
it doesn't matter if it is soft or hard,
round or square...**



**...we can provide our experience
in cheese cutters manufacturing
everywhere in the world!**



FACCHINETTI
IMPIANTI CASEARI

ITALY Via Case Sparse, 14 - T.Q. 28100 Novara (NO)
Phone: +39 0321 455192 - Fax: +39 0321 491651
www.facchinettinovara.it





SEMI-AUTOMATIC CUTTER FOR EXACT WEIGHT WEDGES PR_01

- Semi-automatic equipment to cut exact weight wedges starting from round cheeses
- Cutting programs available: number of wedges * exact weight (Min. 50 Grs.)
- Cut is made with stainless steel or ultrasonic blade
- All stainless steel AISI 304/316 * Plc Siemens * Teleservice system
- Max cheese dim. : diam.450xH150 mm.
- Max cutting speed: till to 45 ppm

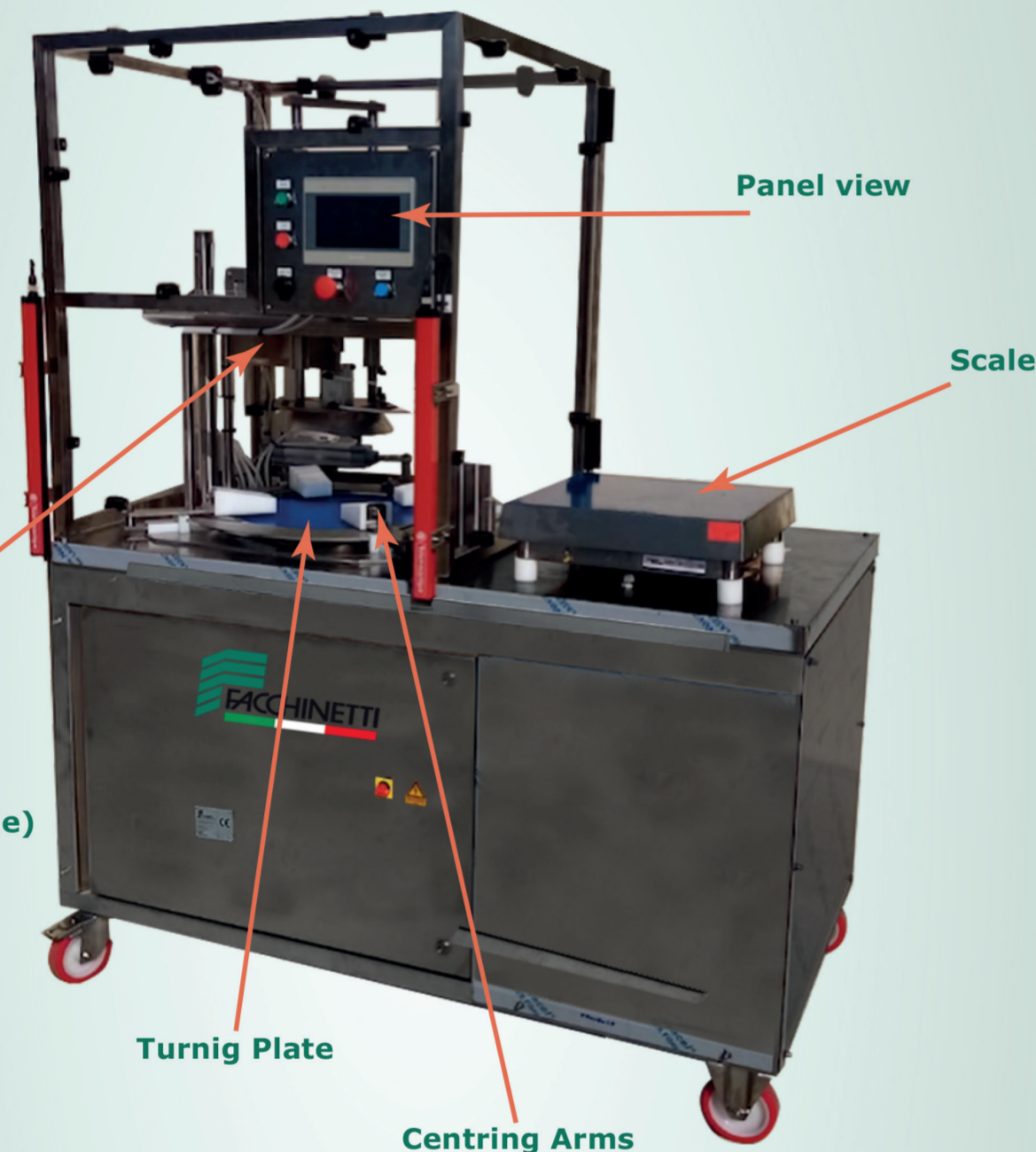

- Available models:**
- LPR_02 Corer + wedges cutter
 - PR_02 Wedges cutter + unloading system

FACCHINETTI
IMPIANTI CASEARI

ITALY Via Case Sparse, 14 - T.Q. 28100 Novara (NO)
Phone: +39 0321 455192 - Fax: +39 0321 491651
www.facchinettinovara.it

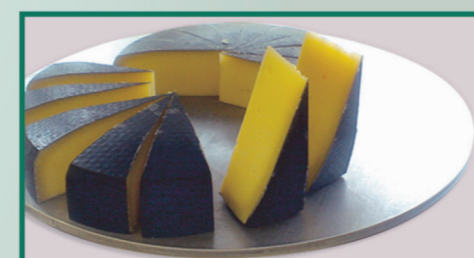

TECH4FOOD MAGAZINE

DESIGN • KNOW HOW • INNOVATION • VISION

Managing director: Angelo Frigerio

Edizioni Turbo Srl - Corso della Resistenza, 23 - 20821 - Meda (MB) - Tel. +39 0362 600463/4/5/9 - Fax. +39 0362 600616 - Periodico bimestrale - Registrazione al Tribunale di Milano n. 2 del 4 gennaio 2018 - Stampa: Italgrafica - Novara - Poste Italiane Spa - Sped. in Abbonamento Postale DL 353/2003 (conv. in L. 27.02.2004, n.46) art. 1, comma 1, LO/MI - In caso di mancato recapito inviare al CMP di Milano Roserio per la restituzione al mittente previo pagamento resi.

insight

Once upon a time there was export



An 11.3% drop in the Italian foreign trade is expected in 2020. The worst setback since 2009, when it fell by 20.9%. Depending on the different projections, however, the scenario could improve as early as 2021. The forecasts of the Sace Export Report.

from page 14 to 16

sustainability

Green Tech, Good Pack

Environment protection, energy saving, traceability, waste reduction. Sustainable goals play an increasingly important role in the business of food technology suppliers. In the following pages, some of the latest solutions developed by Italian companies.



from page 24 to 26

Facchinetti

"You do it, we cut it"



The company's range of machinery for the dairy industry is wide and varied. Technical solutions installed all over the world. Thanks to a tailor-made, flexible and dynamic approach.

on page 8

Travaglini

70 years beside the meat industry

Long-standing partner to global food manufacturers, the firm provides its customers with cutting-edge, energy-saving and top performing plants and machines for all stages in the production of raw hams and salami.

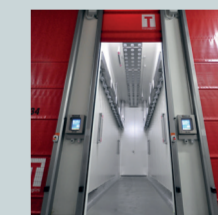

on pages 10 and 11

Gelmini

Tailor made on your cheese



Since its inception 30 years ago, the company's customer-oriented approach has remained unchanged. To provide customers with high performing, cutting-edge processing and packaging technologies.

on page 13

the event

Discover Meat-Tech 2021

on page 9

markets & data

Dairy: a six months outlook

on page 12

the survey

Packaging in supermarkets: sustainable revolution

A good communication is a strong competitive advantage for both manufacturers and retailers. That find in product packs their first and foremost "business card". The key highlights from the Nomisma-SpinLife survey.

on pages 18 and 19

focus on

Plastic & big corps: behind the scenes

A report by The Changing Markets Foundation suggests that the world's largest users have undermined proven legislative solutions to the environmental issue for decades. Capitalising on the Covid-19 crisis.

on pages 20 and 21

zoom

Industrial machinery: Italian engine

Current and post-Covid outlook for a sector worth 230 billion euro to the national economy. The report from Ey, Cdp and Luiss Business School.

from page 22 to 23

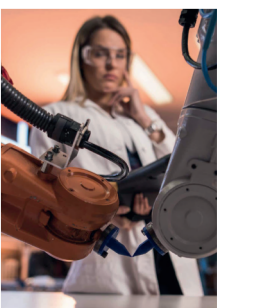



Plastic tax: good things come in three

By Federica Bartesaghi

The Italian plastic tax, a 0.45 cents levy on each kilo of single-use plastics produced was born unlucky. Included in the 2020 Budget Law, it immediately aroused hostility and controversies. Initially established at 1 euro per kilo of plastic produced and then reduced to 0,45 cents/kilo, it was expected to come into force in April 2020, which turned in July 2020 and then, due to the Coronavirus pandemic, it was postponed to January 2021. Now that 2021 is right behind the corner, a new working group established by the Ministry of Economy and the Customs Agency seems to be willing to muddy the waters and cause a new postponement.

During an open-hearing held on the past 28 September, the hypothesis to extend the tax to other players in the supply chain has been introduced, as well as the possibility to change the plastic products interested by the regulation. In detail, wholesalers and retailers could be held responsible alongside with plastic producers; while semi-processed plastic items could be excluded, in favor of a systems that classifies plastics according to their function and finality.

But plastic is not an Italian-only issue. Governments across the continent have also started to impose big fees on plastic products with the aim of disincentivize businesses from using them at all. This is a consequence of the EU Plastic Strategy launched in 2018, which made

of plastic waste management a communitarian priority.

This translated into a ban - voted by the EU Parliament in March 2019 and that will come into force in January 2021 - to the sale of single-use plastic products. The strategies implemented by EU governments to tackle this issue do not differ too much on the subject matter, while have very different timetables.

Some countries have taken on a one-by-one approach, opting to issue targeted bans on specific items, on shorter deadlines, such as Germany's commitment to ban plastic straws by 2021. Others - like France - have opted for a more general approach: the country is aimed at eliminating all single-use plastics by 2040, while simultaneously boosting recycling capabilities.

A number of member states will also put the money collected through the new plastic taxes back into environmentally-friendly projects. For instance, Greece's anti-plastic bill foresees the use of the funds collected for the protection of the country's marine life and its habitat.

Yet, good things come in three and therefore the national plastic taxes and the EU ban on single-use plastics won't come alone in 2021. Next year, a new tax on plastics is due to begin: a cost of 800 euro per ton of non-recycled plastic packaging waste that will be paid by member states into the EU's general budget to support the Coronavirus Recovery Fund.

Plastic tax: non c'è due senza tre

La plastic tax italiana, l'imposta da 0,45 euro al chilo sui manufatti in plastica monouso, è nata sotto una cattiva stella. Inserita nella Legge di Bilancio 2020, ha da subito sollevato pesanti critiche e generato malumori in diversi ambienti. Inizialmente fissata a 1 euro per ogni chilo di plastica prodotta e poi ridotta a 45 centesimi al chilo, la sua entrata in vigore era ipotizzata per aprile 2020, poi fissata a luglio 2020 e in seguito slittata a gennaio 2021 a causa dell'emergenza Coronavirus. Ora che il 2021 è alle porte, ecco che un nuovo gruppo di lavoro istituito dal Mef e dall'agenzia delle Dogane minaccia di spargliare le carte sul tavolo. E determinare, con molta probabilità, un suo ulteriore rinvio.

Nel corso di un open-hearing che si è svolto lo scorso 28 settembre è stata infatti avanzata l'ipotesi di includere nuovi 'oggetti' e addirittura variare gli 'oggetti' del tributo. In dettaglio, si è parlato di coinvolgere nel pagamento altri attori della filiera, come i grossisti o le insegne della grande distribu-

zione. Mentre per quanto riguarda l'oggetto del tributo, l'ipotesi al vaglio è quella di escludere i semilavorati in favore dell'introduzione di un 'criterio identificativo per funzioni', che faccia riferimento alle finalità del manufatto in plastica.

L'annosa questione della plastic tax non è tuttavia una prerogativa italiana. I governi di diversi paesi sono al momento impegnati a istituire imposte più o meno pesanti sui manufatti in plastica, per disincentivarne progressivamente l'utilizzo. Una conseguenza diretta della Plastic Strategy Europea lanciata nel 2018, che ha fatto della gestione dei rifiuti in plastica una priorità comunitaria. E che si è tradotta, a marzo 2019, in una direttiva che mette al bando la commercializzazione di alcuni prodotti in plastica monouso. Le strategie adottate dai paesi per ottemperare a questa direttiva vanno quasi sempre nella stessa direzione. Pur con modalità e tempistiche differenti.

È il caso della Germania, che ha scelto un approccio mirato e si è

impegnata a eliminare dal mercato, per prime, tutte le cannucce di plastica entro il 2021. Altri invece, come la Francia, hanno scelto un approccio più 'generale': il Paese ha fatto sapere che intende eliminare tutti i prodotti in plastica monouso entro il 2040, potenziando nel frattempo i sistemi di raccolta. C'è anche chi si è già impegnato a investire in progetti ambientali i soldi raccolti grazie alla 'plastic tax' nazionale. È il caso della Grecia, che finanzia una campagna per la tutela dell'habitat marino.

Ma come recita il detto, non c'è due senza tre. Ed ecco quindi che le plastic tax nazionali e il divieto comunitario di commercializzare manufatti in plastica monouso non solo le uniche misure che vedranno la luce nel 2021. Una nuova imposta europea è infatti pronta a entrare in vigore a partire dal prossimo gennaio: un contributo nazionale di 80 centesimi al chilo per i rifiuti in plastica non riciclati volto a finanziare il Recovery Fund, il pacchetto di aiuti Ue per superare l'emergenza Covid-19.



Managing director:
ANGELO FRIGERIO
Edited by: Edizioni Turbo Srl
Corso della Resistenza, 23
20821 - Meda (MB)
Tel. +39 0362 600463/4/5/9
Fax. +39 0362 600616
e-mail: info@tespi.net

Periodico bimestrale - Registrazione al Tribunale di Milano n. 2 del 4 gennaio 2018
Edizioni Turbo Srl n° iscrizione ROC11158 del 21 aprile 2005
Numero 8 - ottobre/novembre 2020 -
Stampa: Italgrafica - Novara -
Poste Italiane Spa -
Sped. in Abbonamento Postale DL 353/2003 (conv. in L. 27.02.2004, n.46) art. 1, comma 1, LO/MI -
In caso di mancato recapito, inviare all'ufficio postale di Roserio per la restituzione al mittente che si impegna a pagare la relativa tariffa.
Una copia 1,00 euro
Abbonamento annuo 20,00 euro
L'editore garantisce la massima riservatezza dei dati personali in suo possesso. Tali dati saranno utilizzati per la gestione degli abbonamenti e per l'invio di informazioni commerciali. In base all'Art. 13 della Legge n° 196/2003, i dati potranno essere rettificati o cancellati in qualsiasi momento scrivendo a: Edizioni Turbo S.r.l. Edizioni Turbo S.r.l.
Responsabile dati: Angelo Frigerio
Corso della Resistenza, 23
20821 Meda (MB)

Questo numero è stato chiuso in redazione il 7 ottobre 2020

PACKAGING MACHINES FOR MASKS

Tecno Pack SpA immediately accepted the worldwide need to pack P.P.E. - masks - creating two models of electronic horizontal flow pack machines, suitable for packaging these items.



FP015S
HORIZONTAL WRAPPER

These packaging machines guarantee not only efficiency and speed in packaging, but also very high levels of hygiene, safety and perfection of the packaging.

Versatility of use and format change allows the packaging of masks and other personal protective equipment in single or multi-pack packages.



FP016S
HORIZONTAL WRAPPER

FAST DELIVERY
InfoLine +39 348 931 00 69

Tecno Pack
PACKAGING MACHINES

Via Lago di Albano, 76 · 36015 · Schio (Vicenza) Italy · +39 0445 575 661 · www.tecnopackspa.it · comm@tecnopackspa.it

INVESTINDUSTRIAL ACQUIRES 73.5% OF DELLA TOFFOLA

The Investindustrial investment company has signed an agreement to acquire a majority stake in Della Toffola and DT Invest. The Italian company, founded in 1958 is specialized in the design and manufacturing of machines and automated lines across a range of beverage sectors. Della Toffola is headquartered in Trevignano (Treviso), operates 8 production plants and 9 foreign commercial branches. In 2019 it achieved a turnover of 144 million euros. The brothers Vittorio, Francesco and Luciano Della Toffola, who are the current sole shareholders, will remain minority shareholders with 26.5% of the share capital and will partner with Investindustrial, which will hold 73.5%.



Investindustrial acquisisce il 73,5% di Della Toffola

La holding di private equity Investindustrial rileva la maggioranza di Della Toffola e DT Invest, società trevigiana fondata nel 1958 e attiva nella progettazione e realizzazione di macchine e linee automatiche per il mondo beverage, oltre che sistemi di imbottigliamento e trattamento delle acque. Con otto stabilimenti (di cui sette in Italia) e nove filiali commerciali all'estero, il gruppo Della Toffola ha realizzato, nel 2019, un fatturato di 144 milioni di euro. I fratelli Vittorio, Francesco e Luciano Della Toffola, attuali azionisti unici, manterranno una quota pari al 26,5% del capitale, accanto a Investindustrial che deterrà il 73,5%.

GULFOOD MANUFACTURING POSTPONED TO 2021

Foodservice, machinery and ingredient supplier exhibition Gulfood Manufacturing has been postponed this year, moving the event to 2021 due to Covid-19. The event – expected to take place from 3 to 5 November this year – is therefore moved from 7 to 9 November 2021 at Dubai World Trade Center.

Gulfood Manufacturing rimandata al 2021

Gulfood Manufacturing, evento numero uno in Medio Oriente e Nord Africa per le tecnologie di food processing e packaging, ha 'alzato bandiera bianca'. La manifestazione, che doveva svolgersi dal 3 al 5 novembre presso il Dubai World Trade Centre, ha annunciato che a causa delle incertezze determinate dalla pandemia l'edizione 2020 non si svolgerà. Il nuovo appuntamento è quindi per il 2021, dal 7 al 9 novembre.

CFIA CANCELLED (AGAIN). THE EVENT WILL BE BACK IN JUNE 2021

"Unfortunately, with deep regret, we announce that following the last declaration of the Minister of Health Olivier Veran and the lowering of the visiting number to 1,000 people, the CFIA Rennes (September 29-30 & October 1) is unfortunately cancelled", is written in a note published by the organizers of Cfia, French trade show for the food packaging and processing industry. Initially scheduled for March 10-12 2020, the show was postponed the first time to 26-28 May, at the Rennes Exhibition Center. The second postponement, to 29 September – 1 October, also determined a move in the location: from Rennes to Nantes. Now comes the final rescheduling to 2021, from 8 to 10 June.



Cancellata (di nuovo) Cfia.

La fiera dà appuntamento a giugno 2021 "Sfortunatamente, e con grande dispiacere, annunciamo che in seguito alle dichiarazioni del ministro della Salute Olivier Veran e l'abbassamento a quota 1.000 del numero massimo di visitatori consentiti, il Cfia di Rennes (settembre 29-1 ottobre) è cancellato", si legge in una nota pubblicata sul portale del salone francese delle tecnologie per il food packaging e processing. Inizialmente programmata dal 10 al 12 marzo 2020, la manifestazione è stata posticipata una prima volta al 26-28 maggio, sempre presso la fiera di Rennes. Il secondo spostamento, dal 29 settembre al 1° ottobre, prevedeva anche un cambio di location: dal polo fieristico di Rennes a quello di Nantes. Ora, lo slittamento definitivo al 2021, dall'8 al 10 giugno.

ALL4PACK CANCELLED IN NOVEMBER: THE TRADE SHOW IS MOVED TO 2022

All4Pack, the French packaging trade show, announced the postponement to 2022 of its 2020 edition, initially scheduled for November at Paris Nord – Villepinte. The event, postponed by two years, will therefore take place in November 2022. A decision taken following the recent development of the Coronavirus crisis, and given that many companies have started to reintroduce travel restrictions.



All4Pack non si svolgerà a novembre: l'appuntamento slitta al 2022

Il salone francese del confezionamento, All4Pack, annuncia la cancellazione della manifestazione in programma il prossimo novembre presso il quartiere fieristico Paris Nord – Villepinte. L'evento, rinviato di due anni, avrà quindi luogo a novembre 2022. Una decisione dettata dall'inasprirsi dell'emergenza sanitaria da Coronavirus in diversi Paesi europei, a cominciare dalla Francia. E dalle limitazioni agli spostamenti reintrodotte da molte aziende.

INTERPACK: THOMAS DOHSE NAMED DIRECTOR

Thomas Dohse has been named project director of Interpack, the German international packaging trade show. Dohse, who has been part of the Interpack team at Messe Düsseldorf since 2005 and led Interpack 2017 on an operative level as deputy director, follows Bernd Jablonowski, who rose to the managing board of Messe Düsseldorf as an executive director. The upcoming Interpack in Düsseldorf was postponed from its original date in May 2020 to the following year, due to the Covid-19 pandemic. It will now take place from 25 February to 3 March 2021.



Interpack: Thomas Dohse è il nuovo direttore

Da inizio settembre Thomas Dohse, 50 anni, è il nuovo direttore di Interpack, fiera internazionale delle macchine e delle tecnologie per il confezionamento. Dohse – che opera nel team Interpack dal 2005 e che, in qualità di deputy director, è stato responsabile sul piano operativo di interpack 2017 – subentra così a Bernd Jablonowski, promosso executive director nella direzione di Messe Düsseldorf. La prossima edizione di interpack, originariamente prevista a maggio 2020, a causa della pandemia da Coronavirus è stata rimandata al prossimo anno. Si svolgerà infatti dal 25 febbraio al 3 marzo 2021.

GREEN LIGHT, IN ITALY TOO, TO THE PRODUCTION OF BOTTLES IN 100% RECYCLED PET

Approved on the past October 3 by the Italian State Committee on Environment the amendment to ban the mandatory inclusion of 50% virgin polymer in the production of Pet bottles. "To date, in Italy, if you produced recycled bottles you had to use at least 50% of virgin material: a complete non-sense," said the Senator Andrea Ferrazzi, head of the Italian Democratic Party (Pd) in the Committee and promoter of the amendment. "In the meanwhile, we import thousands of bottles made of 100% recycled Pet from other European countries." A first, transitory phase will take place in 2021, while the new rules will be effective starting from the next Budget Law.

Via libera, anche in Italia, alla produzione di bottiglie in Pet riciclato al 100%

È stato approvato il 3 ottobre in Commissione Ambiente del Senato un emendamento al Dl Agosto per abolire la percentuale minima del 50% di polimero vergine nella produzione di bottiglie in Pet. "Fino ad oggi, in Italia, se producevi bottiglie riciclate dovevi usare almeno il 50% di materia vergine: una cosa insensata", sottolinea il senatore Pd Andrea Ferrazzi, capogruppo del Pd in Commissione Ambiente al Senato e promotore dell'emendamento. "Contemporaneamente, importiamo migliaia di bottiglie per bevande con Pet 100% riciclato da altri paesi europei". Per il 2021 è prevista una fase transitoria e sperimentale dell'applicazione delle nuove norme, che si stabilizzeranno invece con la prossima legge di bilancio.



THE RIGHT WAY OF CURING

OUR BAGS FOR SPECKS ARE THE IDEAL SOLUTION FOR YOUR CURING PROCESS:

- EASY TO USE
- WASHABLE AND REUSABLE
- UNBREAKABLE
- TIME SAVERS
- NO NEED FOR PRODUCT TURNING DURING SMOKING
- CUSTOMIZABLE ON YOUR SPECIFIC PROCESS AND PRODUCT

Feel free contact us for more informations at info@retificionassi.com
More info on www.retificionassi.com



“You do it, we cut it”

Facchinetti's range of machinery for the dairy industry is wide and varied. Technical solutions installed all over the world. Thanks to a tailor-made, flexible and dynamic approach.

by Federica Bartesaghi

Established in the '70s in the city of Novara, in the Piedmont region, Facchinetti is specialized in the design and manufacturing of equipment and plants for the dairy sector, with particular attention to the stages of maturation, cutting, and packaging. “We are a very dynamic, medium-sized company”, explains the company owner, Silvia Facchinetti, “endowed with great flexibility and able to meet the most demanding needs of our customers, by developing tailor-made solutions in a very short time.”

Unfortunately, the company has been directly affected by the current sanitary emergency, that caused the death of Teresiano Facchinetti, the company founder and father of Sil-

via: “This was a big loss, but also a strong stimulus for all of our staff to keep working with even more determination and commitment.” Hence, also during the hardest months of the Pandemic, Facchinetti has never stopped producing and delivering its machines around the world. “Installations and start-ups are often managed from remote”, she explains, “thanks to the use of state-of-the-art technologies and to the maintenance devices installed on all of our machines.”

An export-oriented company
During the last four years the company has drastically increased its global business, with export sales accounting, in 2019, for more than

70% of revenues. “Our machines are exported all over the world... wherever cheese maturing or cutting technologies are required”, said the company owner. “Russia and the United States are, as of today, our most important markets. In Russia, a new company branch – ‘Facchinetti RUS’ – was established on the past October, based in the city of Nizhny Novgorod. In the United States, instead, we have been working for many years with our local distributor, whose headquarters are located in Wisconsin.”

Cutting masters
To develop more and more performing cheese cutting technologies is Facchinetti's core mission:

“Around the world, retailers are asking our clients - that is to say cheese companies - for single-serve cheese portions to be added to their product offer”, Silvia Facchinetti explained. “For this very reason, our most demanded solutions are the exact-weight cutting machines: from the most compact solutions (entry level) to the complete lines, both for cheese wheels and blocks.” The latest innovation developed by Facchinetti in this field is a completely automatic line for cheese blocks, for the production of both exact-weight cheese cuts or slices. “The line includes several innovative technologies – she adds – like 3D mapping of the wheel, ultrasonic titanium blade and weight control.”

AUTOMATIC CUTTING LINE FOR CHEESE BLOCKS TXF06

- Made of stainless steel Aisi 304/316
- Fast changing belts with 'easy hook/unhook' system
- 3D cheese mapping
- Ultrasonic titanium blade
- Max. dimensions of the cheese block to be processed: 500x150x150 mm.
- 4 cutting programs
- Min. weight of each portion: 50 gr.
- Min. thickness of the slice: 2 mm
- Max. speed: 66 ppm
- CPU Siemens 1500
- equipped for remote maintenance
- HMI in your language of choice



A BROAD RANGE OF SOLUTIONS

- cheese maturing equipment (dry salting, brushing, washing, skinning, blue cheese piercing, brining, scraping)
- round and block cheese cutters (pneumatic cutters, electro-pneumatic cutters, exact weight wedges compact/automatic cutters, wheel cutters)
- special cutters (cheese dicing, sticks, flakes)
- packaging equipment (thermosealers with Map/trays sealers, vacuum packaging machines and wrapping equipment)
- layering equipment



The company's headquarters

Specialisti del taglio

Attiva dagli anni '70 nella progettazione e costruzione di macchine e impianti per il settore caseario, Facchinetti vanta una forte specializzazione nelle tecnologie per la porzionatura dei formaggi, sia a peso fisso che variabile. Un'expertise oggi esportata in tutto il mondo, con le vendite all'estero che rappresentano il 70% del fatturato aziendale. Un business che l'azienda è stata capace di portare avanti con impegno e dedizione anche durante i mesi più duri della pandemia, grazie anche all'utilizzo di tecnologie di ultima generazione. Il racconto della titolare, Silvia Facchinetti.

Discover Meat-Tech 2021

The latest trends in the meat and dairy industries – and the related packaging and processing technologies – will be on stage at the 2021 edition on the Italian trade show. At Fiera Milano from 17 to 20 May 2021.

by Federica Bartesaghi



THE STATEMENTS FROM EXHIBITORS

GHERRI MEAT TECHNOLOGY

Gabriele Gherrì

“The decision to confirm our participation as exhibitors at Meat-Tech is connected with the need to present to a specific audience our versatile and high-quality offer, like Seydelmann's cutting-edge cutting technologies, or Alco's cooking solutions for a wide range of products, as well as Trivision's food safety applications. All of these technologies can be implemented in different sectors: from meat and dairy processing to the production of ready meals.”

TRAVAGLINI

Federica Travaglini

“To us, Meat-Tech is a strategic event to present our wide range of technologies and solutions. Hence, thanks to the experience gained over years of technological development together with our clients, Travaglini can satisfy any production need, not only for the meat and cured meat industry, but also in the manufacturing of cheeses. All of our plants are projected to offer the best performance for each product, with a strong optimization of energy consumption and costs.”



Environmental awareness, food safety and technology. These will be the main themes addressed by Meat-Tech, the Ipack-Ima trade show dedicated to processing and packaging solutions for the meat industry, for manufacturers of ready-meals, and for similar industries too, like the dairy one. The world largest food supply chains are indeed searching for value added, high efficiency technological solutions. To this purpose, a total control of the supply chain, the digitalization of production and packaging systems as well as product quality and traceability will be highlighted during the event, held at Fiera Milano from 17 to 20 May 2021. The contemporaneity with Tuttofood, the international food & beverage trade show, will provide a one-of-a-kind opportunity to explore the big trends that are shaping the sector at 360 degrees.

Looking for sustainability

According to the Nomisma observatory “The world after lockdown”, between March and May 2020 about 30% of Italian consumers purchased organic products. 20% paid great attention to manufacturing technique respectful to the environment and to sustainable packaging. Environmental awareness has therefore shifted from products to packs: 9 consumers out of 10 are convinced that organic products should have an environmentally-friendly packaging. 36% of consumers expects those packs to be fully recyclable, and compostable for another 17%. 11% of consumers, instead, asks for detailed information on the environmental impact of the pack directly on it. A ‘green’ trend that directly affects both the meat and dairy industries, where innovation plays a key role to identify and anticipate the new consumption trends.

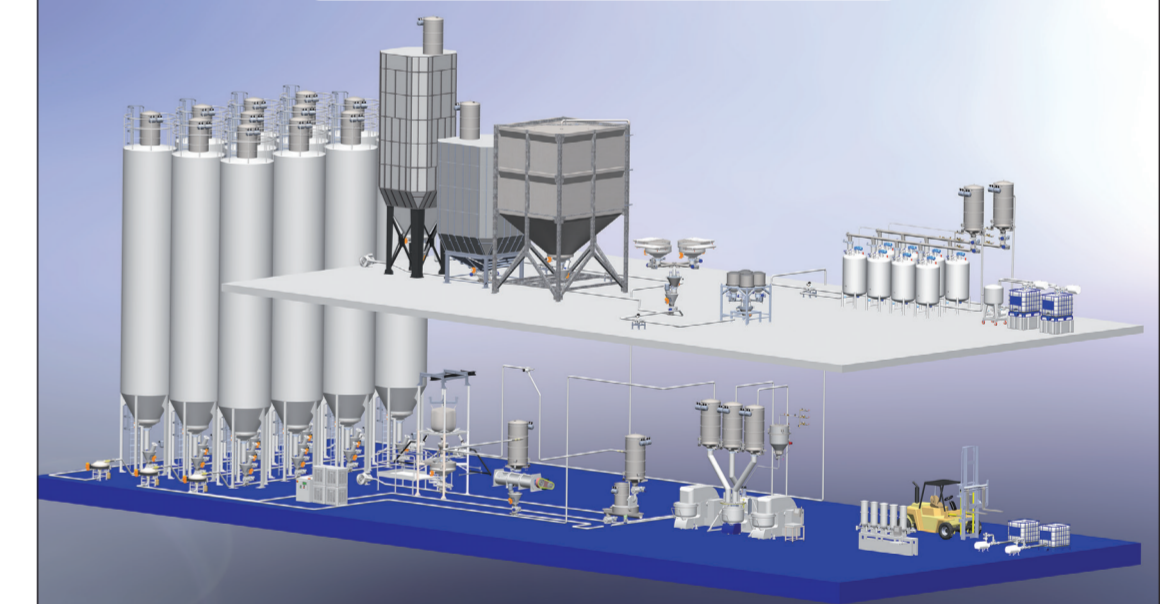

B&B SILO SYSTEMS, THE SOLUTION FOR YOUR IDEAS

We put your ideas into practice, developing tailor-made solutions for you: we design and produce systems to automate the storage, transport and dosing of raw materials, for the food, chemical, pharmaceutical and cosmetic industries. We work with you from the pre-design to the post-sales stage, with the main objective of providing you with the system that best meets your requirements and production needs.



B&B Silo Systems s.r.l.
Via M. Buonarroti 3 -
Z.I. Sipro
44020 San Giovanni
di Ostellato
Ferrara, Italy
Tel: +39 (0)533311163
Fax: +39 (0)533319110
info@bebsilos.com
www.bebsilos.com

70 years beside the meat industry

Long-standing partner to global food manufacturers, Travaglini provides its customers with cutting-edge, energy-saving and top performing plants and machines for all stages in the production of raw hams and salami.

by Federica Bartesaghi



Da 70 anni a fianco dell'industria della carne

Fondata a Milano nel 1950, Travaglini è tra i maggiori produttori mondiali di impianti per l'asciugamento, l'affumicatura e la stagionatura dei salumi. Per 70 anni questa azienda a conduzione familiare – oggi giunta alla terza generazione – ha fornito all'industria italiana e mondiale attrezzature dedicate a ogni singola fase produttiva: dalla salagione al riposo, dall'asciugatura all'affumicatura, oltre naturalmente alla stagionatura di prosciutti, salami e altre specialità a base di carne. A cui si sono aggiunte, nel tempo, anche le tecnologie per il trattamento di formaggi e pesce.



Founded in Milan in 1950, Travaglini is a leading Italian designer and manufacturer of fermenting, smoking and drying systems for the meat industry. For over 70 years, this family-run company, now in its third generation, has been providing the major Italian and global producers of cured meats, like hams and salami, with equipment for salting, curing and drying as well as pre-afeing rooms.

An expertise that, with the passing of time, has been extended to other food specialties, with the development of equipment for the aging and maturing of cheese, as well as for the salting, drying and smoking of fish products.

“Since we are suppliers to food producers, even during the hardest months of the lockdown we have never stopped working”, explains the marketing manager Federica Travaglini. “Thanks to the valuable support of our staff – from smart working or on site – we always managed to provide our clients with the assistance needed.”

From Milan to the world

Established in Milan in 1950 by Arnaldo Travaglini, the company has given itself the mission to develop state-of-the-art air conditioning equipment for smoking, fermenting and drying systems for cured meats. Between 1957 and 1965 the company's internationalization process began, by entering neighbor countries like France, Switzerland and Austria, followed by Spain and Greece. After the death of Arnaldo Travaglini in 1965, Lidia, Roberto and Paolo Travaglini entered the family business. During the 70s, new foreign markets were explored, namely Canada, the United States, South America, Australia, the former Soviet Union countries and other countries in Eastern Europe. Now in its third family generation, Travaglini exports to more than 54 world countries, with foreign sales accounting for around 70-75% of total turnover.

Consumers satisfaction comes first

“Thanks to the professional experience gained over 70 years, we are capable to satisfy any production request to design single machines and entire plants using the most advanced technological and in-

formatic knowledge”, highlights Federica Travaglini. Through the years, the company has developed an efficient customer service that closely follows customers in all steps, including the post-sale. “We are directly responsible for the assembling, the testing and the maintenance of Travaglini systems supplied all over the world”, she adds. “Thanks to our highly qualified technological service, we can help our clients in solving all kinds of problems in production.” Today, Travaglini is focused on developing energy-saving solutions that meet sustainability criteria, through a strong research and development program.

A WIDE RANGE OF TECHNOLOGICAL SOLUTIONS

- Smoking, fermenting and drying rooms for sausage and raw hams
- Clean rooms and air conditioning systems
- Stoves for mortadella
- Thawing systems for meats and other food products
- Pasteurization lines, spiral freezers and freezing tunnels
- Cold stores with ecologic Freon, ammonia and glycol
- Climatic lines for cheese and fish

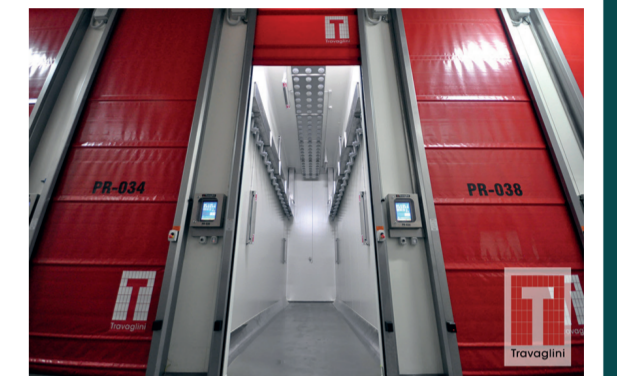

Find out more!

Dairy: a six months outlook

Overall consumption is decreasing, while production is surging. Imports are shrinking too. And China seems to be out of negotiations. The latest data by Robobank analysts.

by Elisa Tonussi



Several markets are still struggling due to the slowdown in demand determined by the closures imposed on the past weeks and months by Governments around the world. Sales, after the boom recorded by the modern retail channel and the total closure of the Horeca channel, seem to be getting back to normal levels. It will take time and current limitations - especially in food service - will prevent a complete recovery, to pre-Covid levels, in the second half of the year. This is what emerges from a report by Rabobank Research, Dutch provider of financial services and market research, related to the second quarter of 2020.

When financial market aids provided by governments will stop, the first real effects of the pandemic on global economy will emerge. Furthermore, in the months ahead the prices of dairy products will come under pressure due to the high volumes stored and the fierce competition linked to the decline in demand for imported products. But it doesn't end up here: China, the world's largest importer of dairy products, will be 'missing' from the market. In fact, in 2020 imports are expected to decline by 15% on an annual basis. In the rest of the world,

however, the weakness of currencies will be a major challenge for imports.

Consumption is going down...

The first quarter of 2020 recorded a positive trend thanks to the surge in retail sales in numerous countries. From April onwards, consumer purchasing behaviors started to normalize, and a weaker - or rather negative - demand is expected in the coming months. So much so that consumption is expected to resume only starting from 2021. Food service, which plays a key role in the decline in demand for dairy products, has suffered unprecedented losses: -50% year-on-year in Australia, -39% in the United States and -30% in China. According to experts, a recovery won't take place until year-end.

... while production is going up

Production in key world areas for the dairy market has increased in recent months. This is a small growth in the historical context: figure show that, against an average of +1.5%, production in the first quarter of 2020 increased by +1.1%. In the second quarter, it fell below +1%, also due to adverse climatic conditions. According to forecasts, it should remain at this level until the first half of 2021.

WHAT'S GOING ON AROUND THE WORLD

US: government aid underway

In the United States a significant increase in the volumes stored was recorded, especially of cheeses and butter. In the last months, an increase in the stock of skimmed milk was recorded too. Indeed, in April milk production in the United States grew 3% year on year. Nevertheless 1% of this surplus was thrown away. In the months ahead, the US government said it will purchase local dairy products: an unprecedented intervention to support the industry, that will be actuated through the direct purchase of products or by providing companies with income support. The US government could, according to forecasts, buy around 2 billion liters of milk in the next two months: a huge amount, and a real rollercoaster for the market.

Europe: funds released for private storage

Farmers in Australia and New Zealand, when the global market is in trouble or crisis, expect interventions in the EU market, according to Robobank experts. An intervention was thus expected from Europe, in particular on the stocks of skimmed milk powder, but it did not take place. However, funds were slowly released for private storage, so volumes on the market, especially for butter and cheese, were reduced.

China: the big 'missing'

In the second half of 2020, a decrease in volumes imported from China is expected but compared to initial forecasts, the decrease will be more contained. In the coming months, Chinese buyers will be the 'big missing' from the sector's world trade. With an average 3% decline in consumption on an annual basis, China is not expected to be in search for commodities until the second half of the year.

Lattiero caseario: il semestre che verrà

Il punto sul mercato mondiale secondo gli analisti di Rabobank. Consumi in calo e produzione in aumento. Ma anche importazioni ridotte. Con la Cina assente dalle contrattazioni.



The company's headquarters

Tailor made on your cheese

Since its inception 30 years ago, Gelmini's customer-oriented approach has remained unchanged. To provide customers with high performing, cutting-edge processing and packaging technologies.

by Federica Bartesaghi

With a 30-year-long specialization in the design and manufacturing of machines and complete systems for the processing and packaging of cheese and deli meats, Gelmini Macchine continues to increase its know-how to meet the modern needs of the food industry. An expertise that, in the dairy sector, covers all kind of cheeses: from hard to semi-hard or soft cheeses, to be sliced at fixed or variable weight.

"Identifying and solving problems, designing new solutions, achieving maximum productivity for customers, anticipating the needs of the market: these are the challenges that each day Gelmini Macchine places at the center of its activities", explains the company from Parma - home to Prosciutto di Parma - located in the heart of the Italian 'Food Valley'. Gelmini has been experiencing constant growth and technological development since its inception, in the '80s. The continuous innovation, the design of tailored solutions and the constant assistance to customers are indeed the key values instilled by its founder, Antonio Gelmini.

Technologies for all needs

After all these years, the company's philosophy is still focused on a customer-oriented approach and the highest technical expertise, combined with a complete range of machines. It includes disk cutter and splitter machines as well as punching machines capable of managing cheese wheels of different sizes and densities. But also cheese cutting machines for both hard and semi-hard large sized cheeses. In addition to that, Gelmini produces complete lines for cheese processing to obtain any desired cheese shapes: wedges, cubes, grated, julienne, flakes and much more.

Reliable global partners

The success achieved on the Italian market, where it cooperates with some of the largest national dairies, goes hand in hand with the internationalization process. Now Gelmini machines are widely used in markets like France, Switzerland and Russia. And exports account for around 25% of the

company's turnover. The company's 'best selling' technologies on a global scale are those dedicated to fixed-weight cheese cutting, like the ultrasonic Arpa line for soft and semi-soft cheeses. Highly appreciated on global markets also the industrial grater mod. Occhio di Tigre, which grants high productivity and easy cleaning.

Customer satisfaction is a commitment

Facilities and activities entirely devoted to customer support are available at the company's headquarter. In detail, it includes a laboratory equipped for the revision and maintenance of production machines; a spare parts warehouse to promptly supply customers around Italy and all over the world; a team of specialized engineers who carry out routine visits and scheduled maintenance and on call for urgent interventions; and a team dedicated to technical training and to the instruction of customers for newly purchased machines or in case of functional changes and machine upgrades.

MOD. ARPA ULTRASONIC CUTTING MACHINE

A machine characterized by high productivity, versatility and high cutting precision - due to efficient vision systems, also with x rays. Equipped with an ultrasonic cutting system to work with soft cheeses of different sizes (from ø 250 to 650 mm.), Arpa is completely made of stainless steel with cantilever tapes (to facilitate cleaning), equipped with a 3D scanning vision system installed in the cutting area, which allows to process irregular shaped wheels; and of a catch weight to run continuously correction of cutting angle to chase the nominal weight.



Gelmini: tecnologie su misura

Specializzata nella progettazione e costruzione di macchine e linee per la trasformazione e il confezionamento alimentare, Gelmini ha sviluppato un know-how speciale nel campo della lavorazione dei formaggi. Un'expertise che l'azienda di Langhirano esporta con successo nel mondo, dove tra le tecnologie più richieste figurano oggi le macchine per la porzionatura dei formaggi a peso fisso.

Once upon a time there was export

An 11.3% drop in the Italian foreign trade is expected in 2020. The worst setback since 2009, when it fell by 20.9%. Depending on the different projections, however, the scenario could improve as early as 2021. The forecasts of the Sace Export Report.



C'era una volta l'export

Attesa una contrazione dell'11,3% per il nostro commercio internazionale nel 2020. La peggiore battuta d'arresto dal 2009, quando il crollo fu del 20,9%. Lo shock della pandemia si è infatti innestato su un quadro dei rischi già piuttosto 'affollato': le tensioni commerciali tra Stati Uniti e Cina, le incertezze legate alla Brexit o alle crisi sociopolitiche ed economiche in Medio Oriente. A seconda dei modelli previsionali, però, lo scenario potrebbe migliorare già dal 2021. Le previsioni del Rapporto Export di Sace.

A bad year for Italian exports. How bad, however, will depend on the progress of the pandemic in the last part of 2020. And from the imposition - or not - of new containment measures to stem the contagions. Presented on the 10th September in live streaming, the 2020 edition of Sace's annual Export Report tells of a more and more fragile global economy.

The Pandemic added to a long series of emerging risks: trade tensions between the United States and China, the uncertainties related to Brexit and the socio-political and economic crises in the Middle East. During 2020, the global picture has changed drastically. The outbreak of the pandemic and the 'great lockdown' in the first part of the year has led to a more heterogeneous and uncertain scenario, with some economies in slow recovery and geographical areas still deeply involved in the emergency.

"More indebted, less globalized, more digitized. This is how the post-Covid world will be," said the president of Sace, Rodolfo Ettore. "Export is the engine of

our country and in the past, in times of crisis, it gave us the strength to resist. And I am sure it will represent a key driver also in this long awaited restart." State representatives - the Minister of Economy Roberto Gualtieri and the Minister of Foreign Affairs Luigi Di Maio - and entrepreneurs: Oscar Farinetti, founder of Eataly and Alessandro Profumo, CEO of Leonardo, also gave their contribution to the presentation.

A gloomy outlook for year-end

Despite the geopolitical uncertainties of 2019, Italian exports of goods recorded a 2.3% growth in value, thanks to the good demand from non-EU markets (+3.9%), and a weaker demand from EU countries (+0.8%).

"In our base scenario, which in our opinion has the highest probability of occurrence, Italian exports of goods are expected to shrink in 2020: -11.3% to 422 billion euros. The lowest growth rate in exports since 2009, when foreign trade fell by 20.9%," said Sace's chief economist, Alessandro Terzulli. "The data for the

first six months of the year show a 15.3% decline compared to the same period in 2019, but we expect a robust recovery starting from 2021 (+9.3%) and a relatively sustained growth trend in the two following years (+5.1%). This will result, at the end of the forecast horizon period, in 510 billion euro of global sales". As regards the Italian export of services, after the collapse recorded in 2020 (-29.5% in the first quarter of the year), mainly due to the paralysis of tourism, a return to pre-crisis levels is expected as early as next year.

The analysis of key sectors...

A strong contraction, yet followed by a substantial recovery will be recorded in the export of rubber and plastic products (-16.5% in 2020, +13.5% in 2021). A much lighter impact, mainly thanks to the phar-

maceutical business, will be instead recorded by the chemical industry (-1.7% in 2020, +8.7% in 2021). As far as concerns consumer goods, exports in the fashion industry - severely affected by the 'great lockdown' - are expected to decline by 17.2% in 2020 and to recover slowly in the following year (+6.7%). For capital goods accounting for 38% of exports in 2019, which includes automotive, mechanical engineering and electrical appliances - the recovery will be slower. Exports are therefore expected to decline by 10.8% in the current year; in 2021, however, a 9.4% growth is expected.

One of the sectors less impacted by the sanitary emergency is the agri-food sector, thanks to the continuity of production and sustained demand in almost all distribution channels. A decline of 5.4% is expected as well as a rapid recovery next year

(+8%). A relatively smaller drop is also expected for the export of agricultural commodities (-8.3% in 2020), followed by a quick recovery in 2021 (+9.1%).

...and markets

In the analysis of the destination markets of our exports, advanced Europe and North America (USA and Canada) - which together account for more than 60% of Italian international sales - will suffer the strongest contraction this year (with an average decrease of 11.4% and 9.8% respectively). Emerging European countries and markets in the CIA are expected to perform definitively better, also thanks to a relatively small decline this year (-8.1%). In these regions, sales of Italian goods will reach and exceed the levels of 2019 starting from 2021. (...)

follow on page 16

New Line Teriyaki sauces

Pagani Chef

etniké Teriyaki
etniké Teriyaki Impermeneabile

AN AUTHENTIC JOURNEY INTO TASTE

Travel is an experience that involves all the senses, first and foremost Taste. Our new water-soluble and allergen-free Teriyaki marinades, the first two products of the new Etniké Line, will add a unique taste to all your meat and fish products. Try them now! Let us take you to surprising, faraway places.

WITHOUT SOY
WITHOUT ALLERGENS
WATER SOLUBLE MARINADE

www.fratellipagani.it | www.paganichef.it

MINERVA OMEGA GROUP Since 1945, only **MADE IN ITALY**

TODAY, HAMBURGERS (PATTIES) or MEATBALL? MEAT or VEGGIE? Why not both?

New Automatic Hamburger / Meatball forming machine, model C/E HF (Patent Pending).

One and only machine for 3 different solutions:

- Hamburger (Patty) production
- Meatball Production
- Hamburger Stacking Function

Top performance for a really one of a kind machine:

- 3.000 Hamburgers (Patties) / hour
Max diameter: 135 mm
Max thickness: 30 mm
- 6.000 meatballs / hour
Diameter of the meatballs between 25 and 39 mm
- Change of configuration (from hamburger to meatball production) in a few minutes, with a few and easy steps

In addition to processing fish or white and red meat, this machine can be used for the production of veggie burgers, soy or rice meatballs and other mixtures, in line with the modern culinary trends.

IoT (Internet of Things) is already a reality for Minerva Omega Group machines. All this thanks to Nemosy, an innovative technology for monitoring and managing the whole machine inventory remotely from a web platform: control, safety, maintenance.

www.minervaomegagroup.com
laminerva@laminerva.it

la Minerva at Chiodini Mario
OMEGA FOODTECH
Ice-Tek
AIRLESS VACUUM SYSTEMS
ARTEX Food Processing Equipment
CQG
GENERAL MACHINES
RECA
ARSA
WINNER 2000

follow from page 15

Once upon a time there was export

(...) Despite the shock, a return to growth is expected for Asian countries as early as 2021, and an increase in Italian exports to the area by 9%.

The future of Italian exports to Latin America and Sub-Saharan Africa is hard to predict, due to the heavy impact of the pandemic in the first region, and to the fears for an uncontrolled spread of the disease in the second. In Latin America, exports to the six largest economies will drop by around 8.2% in 2020, but in 2021 an average recovery of 7.5% is expected.

Let's get ready to more 'adverse' scenarios

In the 'base' scenario depicted by Sace, 2020 forecasts show a decrease of 11.3 percentage points in the export of goods from Italy. A result affected by the sharp -15.3% posted in the second quarter of the year and not offset by the slight increase recorded in the following months.

The uncertainties connected with the evolution of the sanitary emergency prompted Sace to simulate alternative scenarios based on different (worse) assumptions. A first alternative scenario considers the possibility of a new wave of the virus in the early months of 2021, even in countries where, at the moment, it is in a phase of containment. Another scenario, less drastic but still more negative than the 'base' one, assumes that the restrictions on economic activity and the measures of social distancing currently in place in many countries are loosened more slowly and gradually. In both cases, the collapse of Italian exports would be more severe: -12% or -21.2% respectively. 2021 would therefore no longer be a year of 'rebound', leaving the full recovery of exports to take place no earlier than 2023.

ITALIAN EXPORTS OF GOODS & SERVICES (MLD €; YEARLY % VALUE)



■ Export of goods
■ Export of services

Source: Istat, Ocse, Oxford Economics, SACE.

GROWTH RATES OF ITALIAN EXPORTS FOR MAIN TYPES OF GOODS

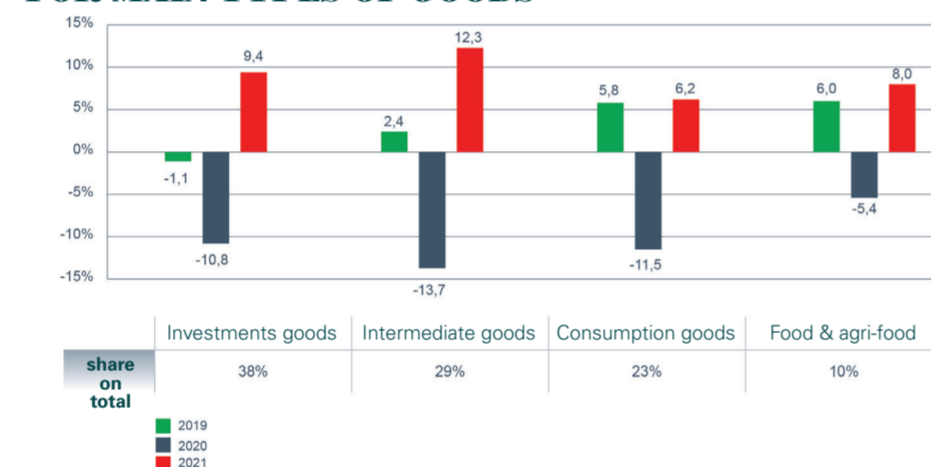

Source: Istat, Ocse, Oxford Economics, SACE.

ITALIAN EXPORTS BY GEOGRAPHICAL AREAS (MLD €; COMPARISON WITH 2019, 2020, 2021)

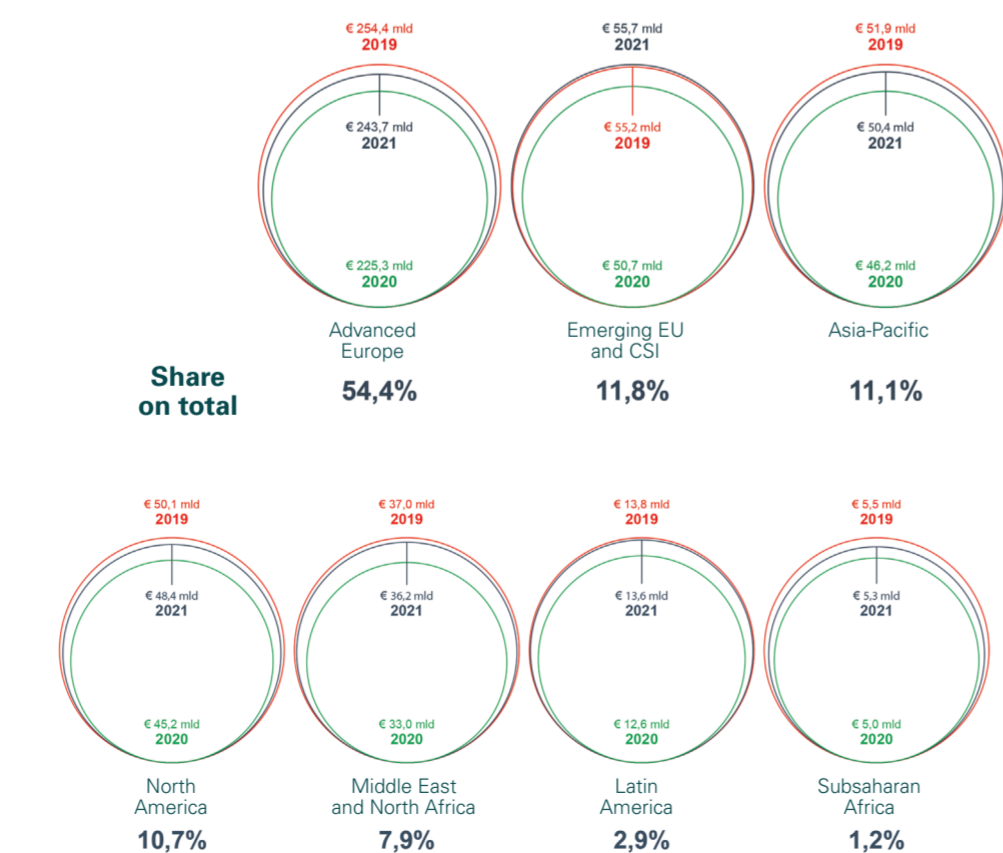

Source: Istat, Ocse, Oxford Economics, SACE.

GH Holding: full speed ahead!

Prosciuttificio San Michele (Terre Ducali), Parma Is and HPP Italia achieved a 17.9% growth in the first 6 months of 2020. And now get ready to face new challenges.

by Federica Bartesaghi

Despite the difficulties imposed by the pandemic, GH Holding doesn't stop and looks ahead. Hence, the negative events and the uncertainty of the global economic context have not affected the growth of a strong and innovative group, which boasts five production plants and includes three 'champion' companies: Prosciuttificio San Michele (Terre Ducali), Parma Is and HPP Italia. Each one specialized in a different sector: deli meats; sandwiches and ready-to-eat goods; high pressure technologies. Strategic sectors for the Italian food industry, and with high growth potential, especially on global markets.



Giulio Gherri

million euro compared to the 43 million of last year".

The reasons behind growth

The three companies - Prosciuttificio San Michele, Parma Is, HPP Italia - are all growing. "For different and complementary reasons they have benefited from the strong growth registered by the deli meat sector (Prosciuttificio San Michele), from the increasingly strong attention paid by consumers to healthy, fresh, and quality products with high value added (Parma Is) and the constant search for greater food safety combined with a longer shelf life, yet preserving the quality level of the product (HPP Italia)", continues the CEO.

Growing despite the crisis

"Our industrial Group has not only closed the first half year and managed the extraordinary situation arising from the Covid-19 Pandemic in a positive way", said the CEO, Giulio Gherri. "It further strengthened its business by recording astonishing performances." The half-year report, indeed, shows revenues of 20,975,969 euro, rising 17.9% over the same period in 2019. "If we consider that the first half of 2019 accounted for a yearly revenue share of 42%," he adds, "2020 estimate is projected to 50



GH Holding: avanti tutta

Nonostante le difficoltà legate alla pandemia, GH Holding non si ferma e guarda avanti. Il gruppo, che vanta cinque stabilimenti produttivi e comprende il prosciuttificio San Michele (Terre Ducali), il produttore di panini e prodotti ready-to-eat Parma Is e lo specialista dell'alta pressione HPP Italia, cresce del 17,9% nei primi sei mesi del 2020. E si prepara a nuove sfide.

HPP ITALIA

it started the second machine (the largest in the world) for high pressure processing in the HPP Italia's Traversetolo plant (Parma province). An investment that turned the plant in the largest European third-party High Pressure Processing center for food products

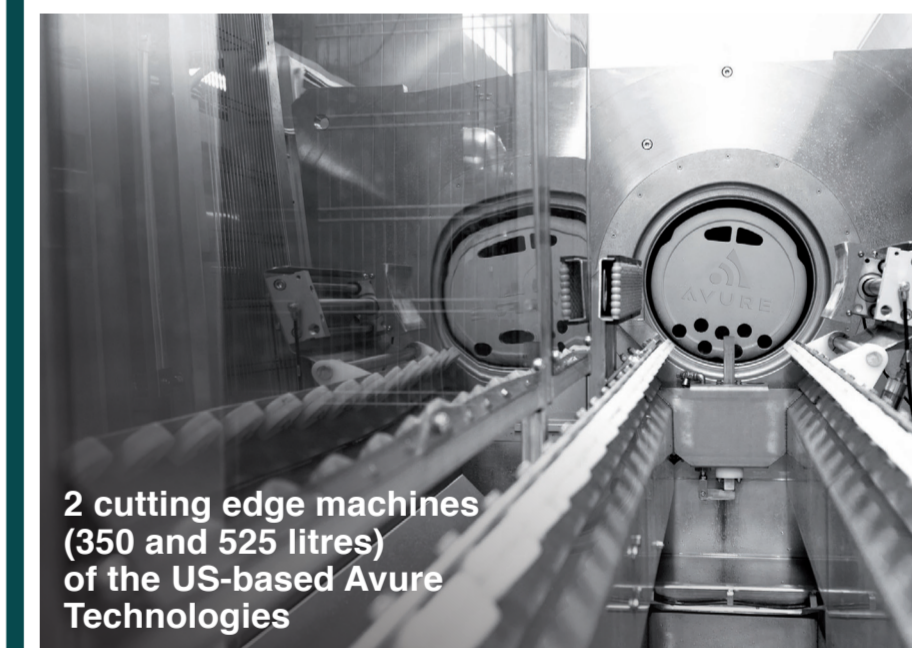
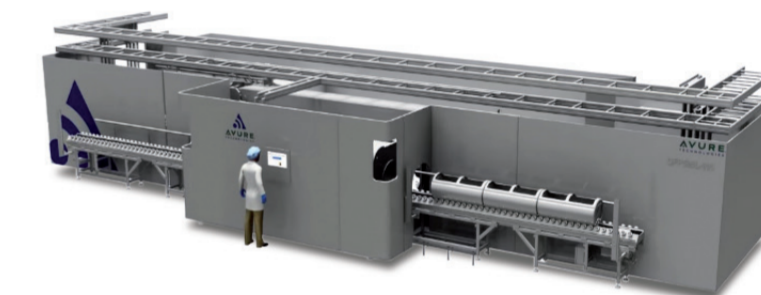

2 cutting edge machines (350 and 525 litres) of the US-based Avure Technologies

The production facilities

Prosciuttificio San Michele-Terre Ducali

15,000 m²
production facilities

11
slicing lines

Parma Is

100,000
sandwiches daily produced

Packaging e Gdo:
rivoluzione 'sostenibile'

Le trasformazioni impresse dal Covid allo stile di vita e alle modalità d'acquisto hanno avuto effetti dirompenti sull'attività di molte aziende e insegne della Gdo. Alcuni asset di crescita strategici, che erano già emersi prima della pandemia, hanno subito un'ulteriore accelerazione. È il caso della sostenibilità, un valore centrale nelle politiche di crescita del Paese e trainante anche su scala comunitaria, in quanto principio fondante del Green Deal europeo. Così come della digitalizzazione, complice la spinta del fenomeno e-commerce. La capacità di comunicare questi valori rappresenta sempre più un vantaggio competitivo strategico per produttori e retailer. Che trovano nel packaging il primo, e più importante, biglietto da visita. Gli highlights della tavola rotonda organizzata da Nomisma e Spin Life lo scorso 28 settembre.

Packaging in supermarkets: sustainable revolution

A good communication is a strong competitive advantage for both manufacturers and retailers. That find in product packs their first and foremost 'business card'. The key highlights from the Nomisma-SpinLife survey.

by Federica Bartesaghi

Held on the past September the presentation of the Observatory on Fast Moving Consumer Goods Packaging Market by Nomisma and Spin Life. With the participation of Silvia Zucconi for Nomisma, Alessandro Manzardo for Spin Life, and the Nielsen analyst Nicola De Carne. The debate was enriched by the contributions of some big players in the food & beverage industry – namely Fileni and Acqua & Terme Fiuggi – together with the packaging multinational Tetra Pak and three large scale retail companies that, for many years now, have been carrying on strategic sustainability plans: Esselunga, Coop and Conad.

"The legislative framework is encouraging both manufacturers and consumers to search for new and alternative packaging solutions," Alessandro Manzardo explains. "One of the most sought after alternative is the substitution of plastic with compostable or renewable materials. Despite this is not always a viable solution. Hence, it could not solve the problem, but shift it to another stage of the life cycle, determining a different kind of environmental pollution. In this regard, a complete Life Cycle Assessment (LCA) is fundamental, just like the role of consumers, that are the last link of this chain."

Territoriality and sustainability: the big purchasing drivers

The changes that the Covid-19 pandemic has impressed on people lifestyle, on the organization of work, and on purchasing habits has had ground-breaking effects on the activities of many companies and retailers. Some strategic growth assets – detected even before the outbreak of the pandemic – were given a further boost. This is the case of sustainability, a matter of primary importance in Italian and European policies, and a founding value of the EU Green Deal.

"The search for sustainability also comes from the 'base' – Silvia Zucconi of Nomisma explains – since consumers are willing to find sustainable characteristics in the products they buy and in the actions undertaken by manufacturing companies alike, with the inclusion of local farmers and the set-up of 100% local or national supply chains."

The impact of these new purchasing habits is soon explained: according to Nomisma, 75% of shoppers chose a supermarket on the basis of its level of sustainability, which includes its Private label offer. First and foremost 'business card' of every retailer. This led to concrete actions, like light-weighting packaging or packaging made from recycled materials or renewable

sources. 'Reduce' and 'replace' seem to be, in this case, the key words of change.

The health crisis is accelerating digitalization

If territoriality and sustainability are the big purchasing drivers, digitalization is another fast developing business. "In the last months the boost to digitalization has concerned both the organization of new working patterns and purchasing habits, with the e-commerce that, in 2020, will reach the record-breaking value of 23 billion euro in Italy, rising 26 percentage points," Zucconi highlights. In the food & grocery sector alone, e-commerce is expected to be worth 2.5 billion euro by year-end, up 56% over 2019.

People love it when it's packed

The number of packed items sold in the Italian large scale retail has increased to almost 45 billion pieces, up by 3.3% over the previous 12 months. For an additional purchase on 1.5 billion packed goods – 1.3 billion more were bought in the first 8 months of the year (1 billion between 17 February and 3 May 2020). "Packaging for fresh food is increasingly demanded, also because of sanitary reasons. It makes the grocery shopping faster and allows for a longer

product storage." By the end of 2019, one product out of five sold in the Italian modern retail had some sustainable features in it, for a total turnover increasing by 2.6 percentage points.

"That of products from sustainable farming and agriculture was the most performing product category," Nicola De Carne explains. "In detail, antibiotic-free products experienced a double-digit growth (+62% over 2018), followed by products from a traced supply chain (+14.7%), those certified Ecocert (+19.6%) and those made with 100% natural ingredients (+9.7%). With regard to packaging, the use of compostable solutions increased by 55.9% last year, followed by packs with a lower plastic content (+21%) and low-carbon pack (+12.9%)."

'Flexible' is better

"In 2019, almost 16,850 tons of packs were produced in Italy," explains Barbara Iacone, of the Italian Packaging Institute. "The weight of every single pack has reduced significantly in the last years, and therefore it is not surprising that the most requested packaging solution is that of the 'super-light' flexible packaging for converters. Paper-based packaging and corrugated card board is also growing fast, mainly enhanced by e-commerce."

PACKAGING USE ON A RISING TREND IN ITALY



FILENI

Simone Santini, chief commercial officer

"The latest packaging innovation introduced by Fileni is a tray completely made of Mater-bi, and therefore compostable, to be recycled in the organic waste. A product very appreciated by retailers and whose values are communicated to consumers in a clear and simple way. Sustainability, for the Fileni Group, is a cultural path that starts from the inside. It is a social commitment, not just a product to place on the market."



ACQUA & TERME FIUGGI

Mirco Gabbin, general manager

"Our company was among the first to put mineral water in bottles, in the early '80s. It was also one of the first to remove it from plastic and put it back in the glass. Now, we are the first to put water in brik, in a practical package made for 75% of cellulose. The cap, instead, is made with a bio polymer. Launched just before the great lockdown as an on-the-go solution, to evaluate the project we will have to wait for the full resumption of mobility."



TETRA PAK ITALIA

Francesco Faella, chairman

"Tetra Pak sells around 4 billion packages in Italy, 190 billion packages around the world. During the Covid-19 crisis, sales increased compared to last year, against a decline in plant engineering. In our strategies we are replacing fossil-based plastics with plant-based plastics. And our ambition - by 2030 or sooner - is to offer the most sustainable packaging solution ever. We aim to decarbonise packaging, to eliminate its environmental impact in terms of Co2."

ESSELUNGA

Antonio Vaccari, Hse manager

"Esselunga is both a distributor and a food company, with an integrated supply chain. We can therefore have maximum control over products and their quality. In recent years we have revolutionized the packaging in the fruit and vegetable aisle by replacing plastic with paper and nets. Where possible, we have also introduced r-pet up to the legal threshold and saved over 1 million tons of plastic a year. But products are not all the same: for meat and fish, for instance, we are studying alternatives but to date we have not found any convincing solution."

COOP

Luciano Villani, head of packaging

"The debate on environmental sustainability, for Coop, began in the 1970s. We have been among the first to abandon palm oil and to have antibiotic-free farms. With regard to packaging, we have been using recycled plastic for water bottles for about a year and for many years packaging light-weighting has been at the top of our priorities. Education also plays a key role: if the efforts made are not communicated, they are useless."

CONAD

Cinzia Linguetti, head of packaging

"With our private label range – around 4,200 products – we are aimed at having a coordinated and clear communication that helps consumers make informed choices. Soon, we will present a range of 6 ice creams packed in paper boxes, that next year will be enlarged with other 6 tastes. The goal is to move from plastic to paper 60% of our private label ice cream range. The hardest part of the transition to sustainability is industrializing such innovations. This is why the collaboration between the packaging providers and the industry is fundamental."



TAILOR-MADE AUTOMATED SOLUTIONS FOR THE FOOD INDUSTRY

Italian manufacturer since 1975, worldwide leader in the concept, design, manufacture and installation of systems for the storage, dosing, conveying and automation of the raw materials for the food industrial production lines.

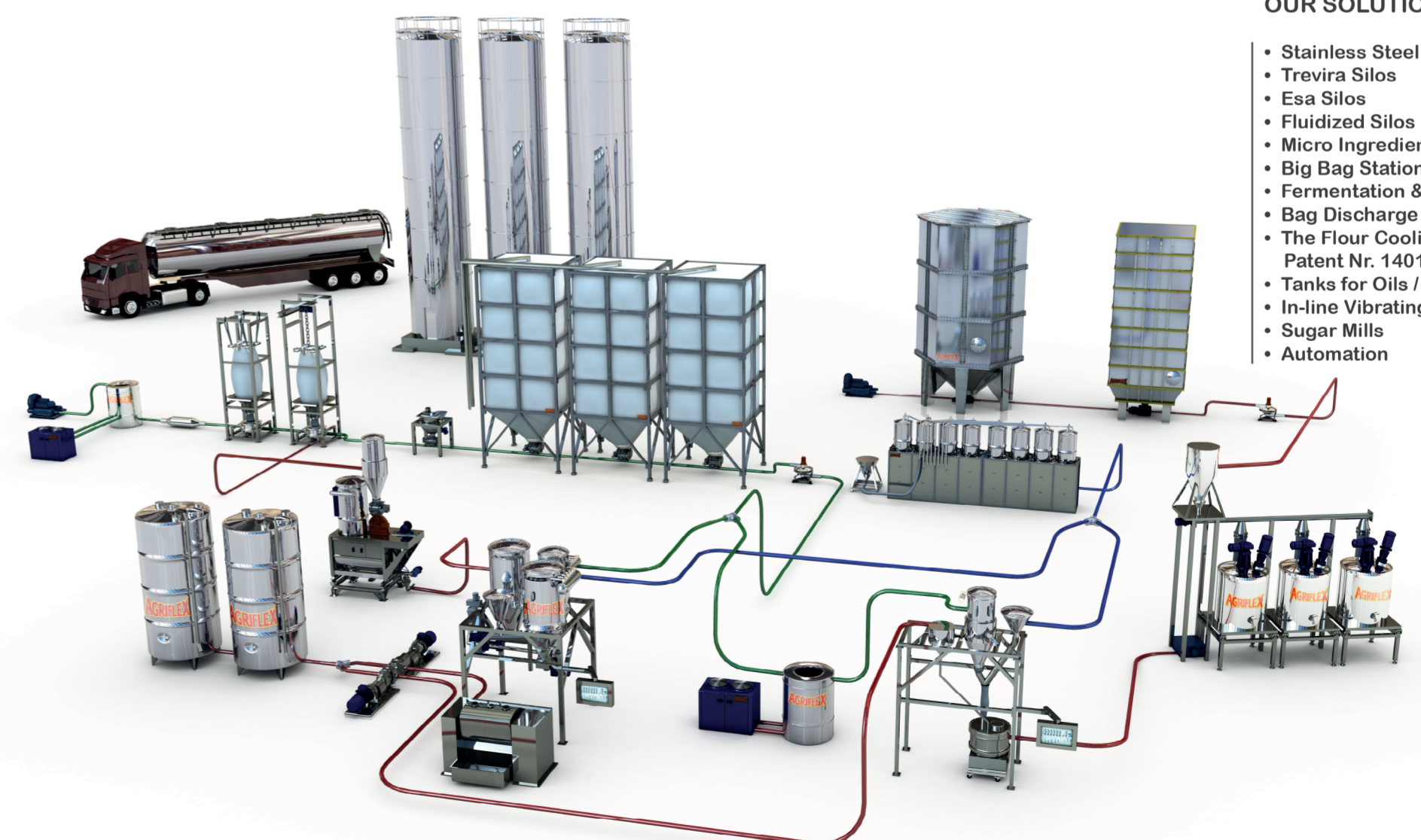

OUR SOLUTIONS :

- Stainless Steel Silos
- Trevira Silos
- Esa Silos
- Fluidized Silos
- Micro Ingredients
- Big Bag Station
- Fermentation & Sourdough
- Bag Discharge emptying
- The Flour Cooling System Patent Nr. 1401347
- Tanks for Oils / Fats
- In-line Vibrating Sifter Vibro-V
- Sugar Mills
- Automation



Plastic & big corps: behind the scenes

A report by The Changing Markets Foundation suggests that the world's largest users have undermined proven legislative solutions to the environmental issue for decades. Capitalising on the Covid-19 crisis.

by Federica Bartesaghi

A new investigative report from The Changing Markets Foundation brings disrepute and discredit to the global plastic industry, suggesting that “behind a veil of nice-sounding initiatives and commitments to address the plastics crisis” big producers, consumer brands and retailers have obstructed and undermined proven legislative solutions to the crisis for decades.

Based on research and investigations carried out in 15 countries across five continents - United States, EU, Scotland, France, Austria, Spain, Czech Republic, Japan, China, Kenya, Uruguay and Bolivia, UK, Portugal and the Netherlands - “Talking Trash: The Corporate Playbook of False Solutions to the Plastic Crisis”, released on the past September, claims that tactics to undermine legislation in individual countries are part of a global approach by Big Plastic to ensure that the corporations most responsible for the plastic crisis evade true accountability for their pollution.

Taking advantage of Covid-19

According to the report, the global health crisis has given a pass to such bad behaviors: since the start of the Covid-19 pandemic, indeed, plastic producers have “co-opted the public health crisis and capitalised on people’s fear to call for regulatory rollbacks on environmental legislation and argue the case for single-use plastic. In many cases they have succeeded.” For instance, many

US states have suspended plastic bag bans and many companies have opted for single-use plastic bags and cutlery, banning or restricting reusables.

“Despite years of industry attempts to distract, delay and derail legislation, at the beginning of 2020 it seems the tide had started to turn against plastic pollution, with governments from Europe to Africa introducing legislation to ban certain problematic single-use plastic products, implement deposit return systems (Drs) and oblige producers to take responsibility for their waste”, the report highlights. “This followed China’s 2018 ban on plastic-waste imports, which sent shockwaves throughout the waste-management industry globally.”

The failure of voluntary commitments

Talking Trash critically analysed voluntary commitments from what it calls “the 10 biggest plastic polluter”. The list includes Coca-Cola, Colgate-Palmolive, Danone, Mars Incorporated, Mondelez International, Nestlé, PepsiCo, Perfetti Van Melle, Procter & Gamble, and Unilever. Together, they have a joint plastic footprint of almost 10 million tonnes per year.

“Companies use these commitments to appear to be part of the solution, while at the same time using trade associations, producer responsibility organizations and even fake environmental groups to aggressively oppose and lobby to delay progressive legislation to tackle the plastics crisis”, the report

says. “Companies also tend to rely on problematic solutions, such as bio-based plastics or chemical recycling, which fail to address the root cause of the problem and may scale up other environmental problems in their wake. Real solutions, such as mandatory collection of packaging, policies to increase reuse and phase out certain problematic plastic types or products, rarely feature in the voluntary approach and are fiercely fought against, if proposed by policy-makers.”

Big Plastic lobbying exposed

Besides brands, Talking Trash also investigated the most prominent group initiatives, such as the New Plastics Economy Global Commitment by the Ellen MacArthur Foundation and the Alliance to End Plastic Waste. To the latter, members have committed 1.5 billion dollars. “While this might sound like a significant amount of money – the report claims – members of the Alliance invested 186 billion dollars into new petrochemical facilities between 2012-2017, and continue to invest considerable amount into new plastic-production capacity.” These groups are also accused of actively delay more transformative legislative actions. “Our analysis”, adds the report, “found a shocking amount of overlap between corporate membership of the initiatives that claim to solve the plastic pollution and trade associations and lobby groups that actively work to undermine ambitious legislation”.

Plastica e multinazionali: dietro le quinte

Specchietti per le allodole. Astute iniziative di greenwashing portate avanti al solo fine di distrarre governi e consumatori nel tentativo di procrastinare, se non impedire, l'introduzione di leggi 'nemiche' della plastica. A questo si ridurrebbero, secondo un'indagine condotta dalla Changing Markets Foundation - che lavora a fianco delle Ong per scovare e denunciare le pratiche commerciali sleali delle 'big corporation' - le tante iniziative ambientaliste condotte da 10 grandi multinazionali del largo consumo negli ultimi 30 anni.



CASE STUDY: COCA-COLA

According to the “Talking Trash” report, The Coca-Cola Company is the biggest plastic polluter in the world, with a plastic footprint of 2.9 million tonnes per year. While it is committed to 10 voluntary initiatives to solve plastic waste, the report claims, it is also a member of at least seven trade associations that “lobbied against deposit return systems or other legislation to regulate single-use plastic.” The report explains: “While, on the surface, Coca-Cola has committed to a ‘World Without Waste’, over the last 30 years it has continuously broken, delayed or shifted the goalposts on most of its impressive-sounding targets. In 1990, for example, the company committed to having 25% recycled content in their bottles, but 30 years later they are only at 10%.”



RS 110
RS 112
RS 114:
the Risco Trio



The active vacuum filler series for small and medium-scale companies.

Risco introduces the RS 100 vacuum filler series dedicated to dynamic meat processors who frequently switch among outstanding-quality sausages, salami, burgers, ready meals, snacks and more.

We invite you to visit www.risco.it to discover the complete RS 100 range.

Main features:

- Gentle filling of the product with the Risco Long Life system
- Vane filling system with large volume
- Simple and intuitive display
- Minimum maintenance costs
- Hopper size 70 - 165 - 260 l



Partner in your success

Risco SpA
36016 Thiene (VI) Italy | Via della Statistica, 2 | Tel. +39 0445 385.911 | Fax +39 0445 385.900 | risco@risco.it



INNOVATION
QUALITY
SERVICES
**PROCESSING
MACHINERY**

www.cuomoid.it

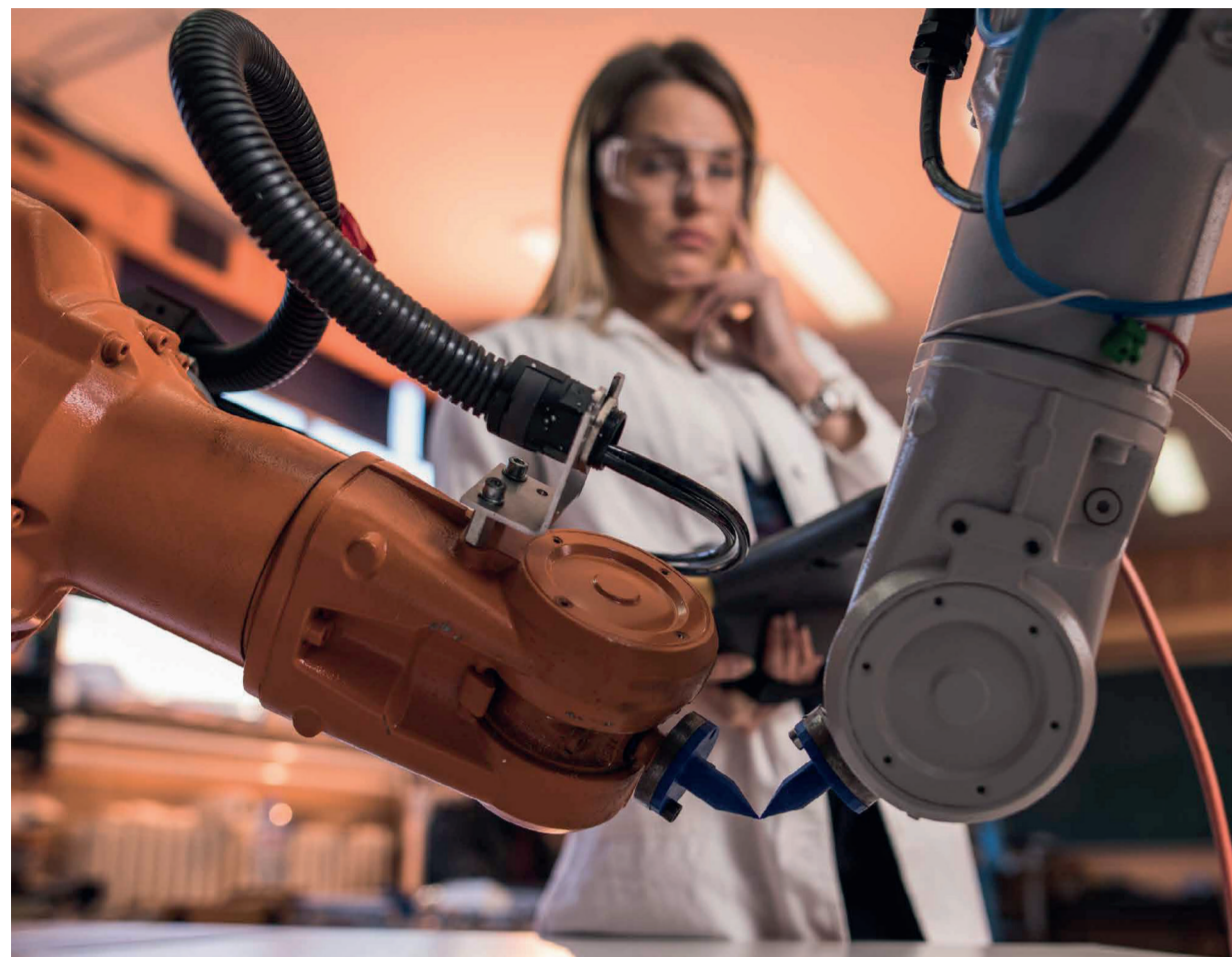

Industrial machinery: Italian engine

State-of-the-art and post-Covid outlook for a sector worth 230 billion euro to the national economy. The report from Ey, Cdp and Luiss Business School.

by Federica Bartesaghi

A quick glance at the data related to the Italian industrial machinery industry is enough to understand why it is so important to the whole country's economy. This 'macro sector', which includes high-tech goods, electrical machinery & apparatus, mechanical engineering and repair & installation of any type of machinery achieves a turnover of over 230 billion euros, generating 28% of the added value of manufacturing and 4.7% of the national added value, thanks to a workforce of 860,000 employees. A strong supply chain, yet not sheltered from the effects of the pandemic, which caused a drop in revenues of between 16 and 23%. A study conducted by Ey, Cassa Depositi e Prestiti (Cdp) and Luiss Business School takes stock of the pre- and post-Covid market situation.

Global outlook: bad, but not too bad

In 2019, the industrial machinery sector generated a turnover of over 12 thousand billion dollars worldwide, equal to 25% of the added value of manufacturing and to 4.3% of world GDP. With at least 18 million workers, the sector employs 2.4% of all world employees. Even before the outbreak of the economic crisis connected with the pandemic, the production of industrial machinery had experienced a sudden slowdown - primarily due to trade tensions between China and the US - with a reduction in the growth rate that passed from 7% in 2018 to 3.6% in 2019. Although 2020 started off better, the Covid-19 sanitary emergency caused the industry's first global contraction after the -9% recorded in 2009. For 2020, a drop close to 2% is expected. Which is bad, but could have been much worse. Sales of high-tech goods - for which a 3% growth is still expected for current year - will indeed attenuate the fall (that otherwise could reach 5 percentage points).

The Chinese surge

The Italian companies active in the industrial machinery sector are a flagship of our manufacturing. In 2019, Italy occupied the sixth place in the global ranking by turnover - after China, the United States, Japan, Germany and South Korea - totaling 260 billion dollars.

Although just 10 years ago, in 2005, global turnover was almost evenly distributed between Japan, the United States and China (which had revenues of 1,100, 833 and 826 billion respectively), between 2005 and 2019 China earned the leadership in almost all the four sub-sectors that make up the industrial machinery industry. Today, China represents a formidable and increasingly less 'out of reach' competitor: with a total turnover of almost 6 trillion dollars (about half the world total), it is the first global manufacturer of industrial machinery, exceeding by more than five times the turnover generated by the second-ranked country: the United States.

Mechanical engineering: Italian excellence

More than high-tech products or electrical equipment, Italy's good positioning on a global scale is connected with mechanical engineering. Alone, it generates 145 billion in turnover (fifth place globally) and employs 466,000 workers out of 860,000. Furthermore, of the 120 billion euro of exports in the Italian industrial machinery's ma-

cro-sector, 82 are generated by products of mechanical engineering, equal to 18% of total Italian exports.

Italy's positioning is also good in the repair and installation of machinery: in this sector our country ranks sixth place globally (third in Europe after France and Germany). On the contrary, our presence is very weak in high-tech, where we occupy only 23rd position.

Italy, where "small is not necessarily beautiful"

Within the industrial machinery macro-category, the subsector that risks to pay the heaviest bill, due to Covid-19, is that of mechanical engineering products, for which a 16% contraction is estimated. This is probably linked with the sector's high internationalization rate, which in previous years made it one of the engines of the country's growth.

Based on an analysis conducted on a panel of Italian companies active in the production and distribution of industrial machinery, the report estimates that, during 2020, the crisis caused by the pandemic could lead to a reduction in the company's revenue of between 16.7% (in a base scenario) and 23.1% (in the more adverse scenario). During the lockdown, around 665,000 workers in the supply chain were affected by the stop to production (77.1% of the total workforce). This interruption has turned into a drop in the hours worked which, in April, were down by -50.2% compared to the same month in 2019. Estimates for 2020 show a possible increase in unemployment in the sector equal to 20.2% in the base scenario and 26.6% in the more adverse scenario.

If once the storm has passed Italy wants to recover its international positioning, the sector needs a strong State intervention in some strategic areas, identified by the report in four 'pillars': the strengthening of capital and financial support; an increase in investments in digital and 4.0 technologies; greater transparency of supply chain management and resilience in business models; and finally the development of partnerships to support the growth of the sector.

"Small is not necessarily beautiful", highlights the director of the Luiss Business School, Paolo Boccadelli: "Today, to stay competitive, different dimensions and intensity of investments are requested to follow certain technological paths. A turning point that can't be achieved only through own and direct investments, but also through company partnerships and aggregations."

LEADING PRODUCERS OF INDUSTRIAL MACHINERY BY TURNOVER (2019, BLN US DOLLARS)

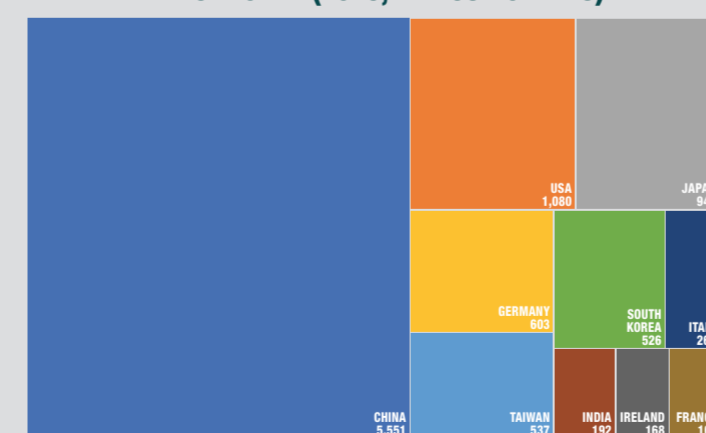

Source: CDP Think Tank elaborated on Oxford Economics data

THE ITALIAN INDUSTRIAL MACHINERY INDUSTRY MACRO-SECTOR INCLUDES:

1

| high-tech goods |

2

| electrical machinery & apparatus |

3

| mechanical engineering |

4

| repair & installation of machinery |

Macchinari industriali: motore del Paese

Basta uno sguardo veloce ai dati che delineano le dimensioni dell'industria italiana dei macchinari industriali per capirne l'importanza per il sistema Paese. Questo macro comparto, che racchiude in sé prodotti e apparecchiature elettriche, prodotti di ingegneria meccanica e riparazione o installazione di qualsivoglia tipologia di macchinari realizza un fatturato di oltre 230 miliardi di euro, generando il 28% del valore aggiunto della manifattura e il 4,7% del valore aggiunto nazionale, grazie a una forza lavoro composta da 860mila addetti. Una filiera forte, ma non per questo al riparo dagli effetti della pandemia, che ha provocato un crollo dei ricavi compreso tra il 16 e il 23%. A fare il punto sul pre e post Covid uno studio condotto da Ey, Cassa depositi e prestiti e Luiss Business School.



Heart of technology



Bulk-handling systems for the food industry since 1985

Product and process analysis
Engineering and control
Direct manufacture
Project management
Installation and commissioning
Monitoring and service

www.cepilos.com
www.cepilos.com/contact
f in cepilos



Green Tech, Good Pack

Environment protection, energy saving, traceability, waste reduction. Sustainable goals play an increasingly important role in the business of food technology suppliers. In the following pages, some of the latest solutions developed by Italian companies.

Across the world, consumers are searching for grocery products – meat or cured meats, cheeses or drinks, sweets or snacks – with strong sustainable features. Organic and locally-sourced food, but also antibiotic-free products respectful of the animal welfare, are some of the most sought after values. A sensitivity that, beside products, is interesting processing and packaging technologies too. In the latter segment, in particular, machine-material combination has become essential.

According to a recent survey by Nomisma, 9 consumers out of 10 think that – to be consistent with their principles – organic products should have a green packaging: 36% of respondents want the pack to be 100% recyclable; 15% want it to be compostable; 11% want to find information about the packaging's environmental impact directly on it.

That's why big tech companies are currently studying and developing packaging systems capable of handling the new packaging materials, are they biodegradable, renewable or plant-based. In the following pages, some of the latest 'green' solutions developed by Italian companies.



AMS FERRARI
www.amsferrari.it

Infinity Series by AMS Ferrari

Fields of application
Filling line

Description and sustainability features

The Infinity Series by AMS Ferrari is the filling line suitable for bottling disinfectants gel, foamy, dense and delicate liquids, corrosive and non-corrosive liquids. This filling line, equipped with the filling technology named 'Flow-Meter' ensures high performances in terms of precision and of reducing product waste thanks to a specific software. Rotative or linear bottling solutions, productivity from 1,000 to 12,000 bph, connection set-up for the sanitizing treatment (Cip/Sip)

☞ **High performances in terms of precision and of reducing product waste**

GRUPPO FABBRIG VIGNOLA
www.gruppofabbri.com

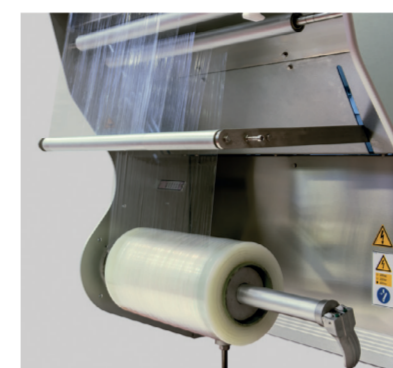

Nature Fresh

Fields of application

Packaging of fresh and very fresh food products in trays.

Description and sustainability features

Nature Fresh is the complete packaging solution with composting certifications based on the combination of a certified compostable cling film with high-productivity wrapping machines.

Designed to present the products in the best possible way, safeguarding all their properties, Nature Fresh is the first cling film in the world, for both automatic and manual packaging, which can boast at the same time industrial and domestic composting certifications.

Automac NF wrapping machines exploit the characteristics of this film combining it with equally compostable or recyclable labels and trays (cardboard, plastic, bioplastic, balsa wood, cellulose paste...). Compatible with all stretch films available on the market (PVC, PE, biobased, compostable) also in their printed version. Reel replacement time: less than 45 seconds.

☞ **Complete packaging solution with composting certifications**



SACMI
www.sacmi.com

Ready-to-use tethered solutions

Field of application

Beverage

Description and sustainability features

Tethered caps (i.e. caps that do not detach from the container after opening) are a legal requirement imposed by the EU to drastically reduce the dispersion of plastic into the environment. All manufacturers must comply with this new standard by 2024. Sacmi has developed a ready-to-use, simple and low investment solution easy to implement on existing lines and flexible enough to manage different cap designs to cope with future changes in consumption patterns.

Sacmi has already developed and marketed tethered cap manufacturing solutions for both screw-off and threadless snap caps that remain hinged to the bottle. The latest cap design for the GME 30.37 standard, developed for 26 mm necks, allows further weight reduction with respect to previous standards (1881 and 1810 for 28 mm necks) in the order of 1.8 grams.

☞ **Ready-to-use, simple and low investment solution easy to implement on existing lines for the production of tethered caps.**

follow

ESSEOQUATTRO
www.esseoquattro.com



Eco Packaging System

Fields of application

Packaging for fresh food.

Description and sustainability features

Eco Packaging System originates from Esseoquattro's green philosophy and it aims to reduce the impact of packaging on the environment and to increase its recyclability, while maintaining its excellent freshness-preserving properties.

Eco Packaging System currently consists of 3 items: Be Green Ideabrill wrapping paper, Be Green Ideabrill bag, Be Green Oléane bag, which can be combined depending on store needs. Be Green Ideabrill wrapping paper and bag together represent the maximum fresh-preserving potential of the patented Ideabrill formula and it is recommended for cold cuts, cheese, meat, bread products.

The combination of Be Green Ideabrill wrapping paper and Be green Oléane bag is recommended for stores that sell also hot ready meals, bread products, sweet and savoury baked goods, fried foods, sandwiches.

Be Green Ideabrill wrapping paper and bag and Be Green Oléane bag are PEFC™ certified. Be Green Oléane can be recycled with paper products, whereas the basic components of Be Green Ideabrill, paper and treated film, can be easily separated so that both can be recycled.

☞ **Organoleptic properties preserved, with a reduced impact of packaging on the environment**

CEPI
www.cepisilos.com



Custom-made bulk-handling systems with individual analysis of energetic impact

Fields of application

All food markets including pet food, baby food, and functional food.

Description and sustainability features

Cepi has more than 30 years of experience in designing safe, efficient and hygienic custom-made solutions. As direct manufacturer of all equipment in its factory in Italy, working with local suppliers, and focused on providing specialized, turn-key solutions, the company is able to deliver installations that will maximize energy and waste efficiency in all stages of production. Cepi's installations are highly customized and designed to optimise energy consumption with an individual analysis of energetic impact. The pneumatic conveyance employs high-efficiency motors such as IE3 motors to save energy and all technologies from storing to applications such as flour cooling equipment are designed to save energy consumption and consumptions of raw materials.

The storing equipment (silos, hoppers, tanks) are designed to allow chronological extraction with Fifo logic, which greatly enhances waste efficiency and the traceability process. All technologies and components are reliable and resistant over time, with a long life cycle guaranteed by CE marking and contributing to overall resources saving.

☞ **Maximize energy and waste efficiency in all production stages**

FERMENTING, DRYING AND SMOKING ROOMS FOR SALAMI AND PROSCIUTTO

CLEAN ROOMS

THAWING SYSTEMS

SW DATA ACQUISITION FROM THE MICROPROCESSORS

AIR CONDITIONING FOR PROCESSING AREAS

OVENS FOR MORTADELLE AND HAM

QUALITY CONTROL IS AT THE HEART OF IT ALL

RESEARCH, EXPERIENCE AND RELIABILITY SINCE 1962

FRIGOMECCANICA

FRIGOMECCANICA S.p.A.

Via Provinciale 19 - 43038 SALA BAGANZA (PR) Italy

Tel. +39 0521 835666 • Fax +39 0521 834070

info@frigomeccanica.it • www.frigomeccanica.it

f Frigomeccanica S.p.A.
 in Frigomeccanica S.p.A.

COLIGROUP (COLIMATIC)
www.colimatic.com

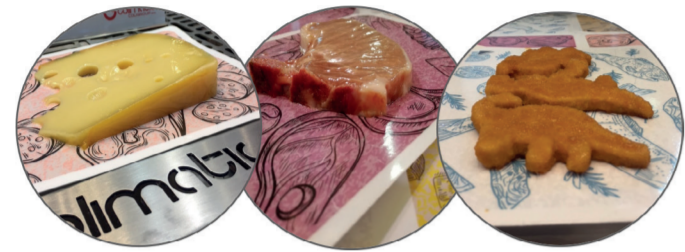

Thermoforming packaging lines Thera Webskin

Fields of application

Colimatic packaging solutions can be used for any kind of fresh or seasoned food product, with steering fluid, in bars, sliced, grated or julienne, in wedges or cubed; in MAP, shrink or skin packaging.

Description and sustainability features

Colimatic Webskin (patented) is the solution to have environmentally friendly packaging without compromising on costs. In the face of global environmental change and its emerging challenges, sustainable development meets the needs of the present without compromising the ability of future generations to meet their own needs.

Colimatic has developed a packaging project that combines the efficiency and hygiene of thermoforming process with the packaging design of tray-sealing and optimized usage of plastic material. The outcome is a package composed for 90% of recyclable cellulose with printed and customizable graphics made from a reel, thus eliminating the costs of storing and managing pre-cut cardboard. The skin packaging is realized on a high-quality cardboard sealed with a high-barrier plastic film to keep intact nutritional and organoleptic features of the product. A smart easy-peel allows the perfect separation between the two layers in order to be properly differentiated.

☞ **Environmentally friendly packaging without compromising costs**

DOLZAN IMPIANTI
www.dolzan.com



Vertical packaging machine for sustainable film

Fields of application

Food products.

Description and sustainability features

Dolzan Impianti produces vertical packaging systems since 1962. Decades of experience in the packaging field has led the company to constant update in order to satisfy the various market needs. Dolzan packaging lines allows to use every kind of thermosealing material: recyclable films, compostable films and biodegradable films.

The fields of application cover the food sector with products such as flours, food powders, rice, coffee, legumes, pasta, candies, pet food, frozen products, food supplements and many others. The versatility of the Dolzan systems matches the peculiarity of every product in bulk, making every machine customized.

☞ **Packaging machines suitable for recyclable, compostable and biodegradable films.**

IMA - IMA ACTIVE DIVISION

www.ima.it/confectionery/active



GS coating equipment

Fields of application

Confectionery.

Description and sustainability features

GS coating equipment is IMA Active reply to accomplish the coating process efficiently and reliably. Efficiency is achieved thanks to the balance of three factors: optimal mixing, accurate spraying and controlled air drying. Firstly, the solid wall drum, with popular Pellegrini shape, finishing and welded baffles, is designed to ensure the perfect mixing of the cores and the homogeneous distribution of the syrup.

Secondly, the spraying system allows an accurate dosage of the syrup: only the needed quantity of syrup is atomized directly on the cores, minimizing losses on the drum.

Thirdly, IMA patented drying system can be flexibly configured either with blowing tube or moving paddles according to the confectionery cores to be treated. This generates a controlled and sized air flow able to let you reach the desired final product in shorter times.

Combined with fast cleaning operations, due to the smooth surface of the pan, all these features ensure high efficiency with minimum consumption.

☞ **High efficiency with minimum consumption**

CASEARTECNICA BARTOLI

www.caseartecnicabartoli.it



Agitator for mixing milk completely in stainless steel - oil free

Fields of application

Cheese and dairy.

Description and sustainability features

The Agitator for Parmesan & Grana cheese, made entirely in stainless steel, is an absolute novelty in IP65 with brushless motor with permanent magnets low energy consumption (about half the consumption of a standard agitator). Without reducer and without oil inside, it meets the increasingly frequent needs of non-contamination of the product with a relative reduction of the environmental impact.

☞ **Low energy consumption**
☞ **Without oil**
☞ **Non-contamination of the product**

AUTOMATIC CUTTING EQUIPMENT FOR EXACT WEIGHT WEDGES LPR_08

Automatic equipment to cut exact weight wedges starting from round cheeses

Cutting programs available: number of wedges * exact weight (Min. 50 Grs.)

Two cutting heads with stainless steel blades or ultrasonic blades

All stainless steel AISI 304/316 * Plc Siemens * Teleservice system

Max cheese dim. : diam.400xH140 mm.

Max cutting speed: till to 50 ppm



FACCHINETTI
IMPIANTI CASEARI

ITALY Via Case Sparse, 14 - T.Q. 28100 Novara (NO)
Phone: +39 0321 455192 - Fax: +39 0321 491651
www.facchinettinovara.it

EXACT WEIGHT SLICER MOD. TXF_06

Automatic equipment to cut exact weight slices or portions starting from cheese blocks or provolone cheese

Cutting programs available: Thickness (Min. 2 mm) * Exact weight (Min. 50 Grs.)

All stainless steel AISI 304/316 * Plc Siemens * Teleservice system

Max speed: 60 ppm

Max loaf size: 500x150x150 mm.

Panel view

Ultrasonic blade

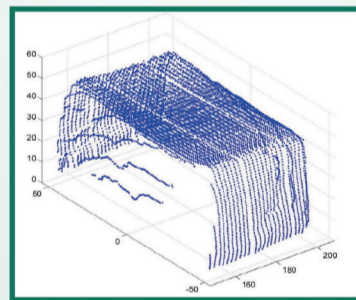
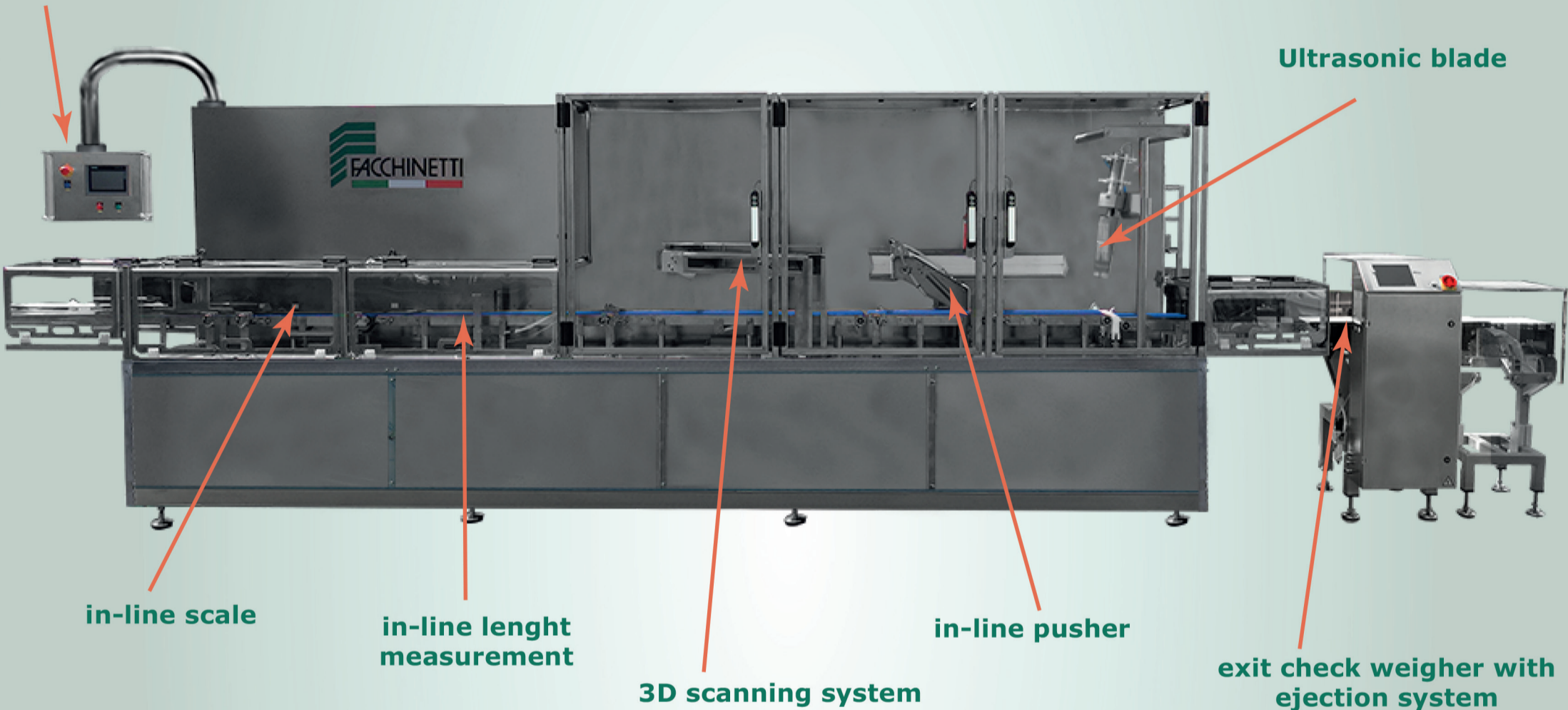

ITALY Via Case Sparse, 14 - T.Q. 28100 Novara (NO)
Phone: +39 0321 455192 - Fax: +39 0321 491651
www.facchinettinovara.it

